

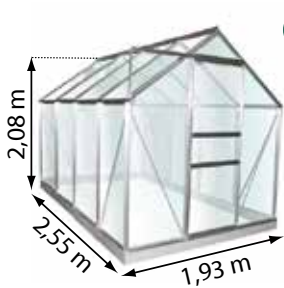

LAMS

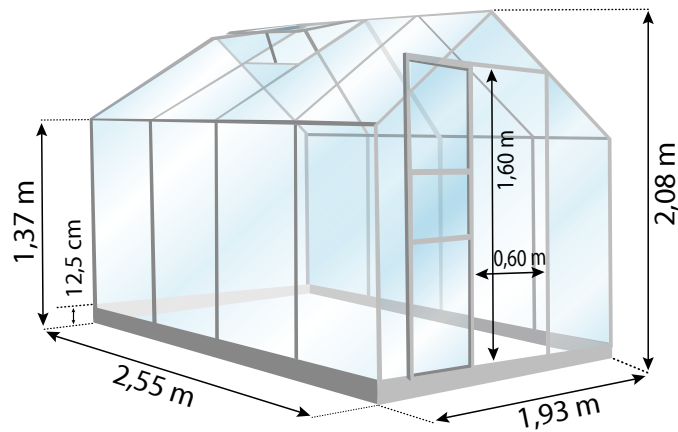

1



2

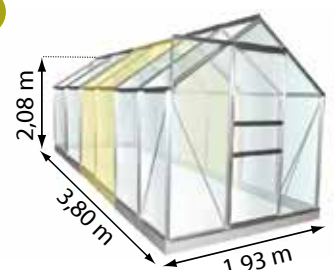

1 Module de base - Basismodul - Basic module
2,55 x 1,93 x 2,08 m (4,90 m²)

2 Extension - Erweiterung - Extension
1,25 x 1,93 x 2,08 m (2,40 m²)

SERRES - GEWÄCHSHÄUSER - GREENHOUSES

ALLIUM 4,90 M² & 7,30 M²



NOTICE DE MONTAGE

IMPORTANT

- Merci de lire ces instructions attentivement avant de commencer le montage de la serre.
- Merci de vous assurer que toutes les pièces mentionnées sur cette notice sont présentes dans le carton et de vérifier les quantités.
- Merci de suivre les étapes dans l'ordre indiqué par la notice.
- Veuillez conserver soigneusement ce manuel de montage pour une consultation ultérieure.

CONSEILS DE SÉCURITÉ

- Veuillez porter gants, chaussures et lunettes de protection pour le montage de la serre.
- Respectez les conseils de sécurité des outils que vous utilisez pour ce montage.
- En cas d'intempéries (pluie, vent, orage...), ne montez pas votre serre.
- La serre doit être montée par 2 personnes.
- Les sachets plastiques et les petits composants sont à tenir hors de portée des enfants. Eloignez les enfants de la zone de montage.
- L'aluminium est un métal conducteur d'électricité, tenez les profilés aluminium éloignés de toute source électrique.
- Tout appareil produisant de la chaleur ne doit pas être stocké dans la serre (barbecue, chalumeau, ...).
- La serre doit être positionnée et fixée sur un sol horizontal et plan, non exposé au vent.
- Vérifiez l'absence de réseaux (eau, électricité, gaz) sous l'emplacement de montage de la serre.
- Attention, ne pas monter sur le toit : risque de chute et de blessures graves.
- En cas de forte chute de neige ne pas laisser la neige s'accumuler sur le toit.

CONSEILS D'ENTRETIEN

- Pour nettoyer votre serre, utilisez de l'eau claire savonneuse.
- N'utilisez surtout pas d'acétone, des nettoyants abrasifs ou autres détergents spéciaux pour nettoyer les panneaux.
- Graissez régulièrement le rail de porte.
- Dégagez le toit de la neige et des feuilles.



SERVICE CLIENTS

Site internet : www.sav-doviris.com



MONTAGEANLEITUNG

WICHTIG

- Bitte lesen Sie diese Anleitung sorgfältig durch, bevor Sie mit der Montage beginnen.
- Bitte stellen Sie sicher, dass alle in dieser Anleitung aufgeführten Einzelteile im Karton vorhanden sind und prüfen Sie die Mengen.
- Bitte folgen Sie den Schritten in der im Handbuch angegebenen Reihenfolge.
- Bewahren Sie diese Anleitung für späteres Nachschlagen sorgfältig auf.

SICHERHEITSHINWEISE

- Bitte tragen Sie bei der Montage des Gewächshauses Handschuhe, Schuhe und Schutzbrille.
- Beachten Sie die Sicherheitshinweise der Werkzeuge, die Sie für diese Montage verwenden.
- Stellen Sie Ihr Gewächshaus nicht bei schlechtem Wetter (Regen, Wind, Gewitter . . .) auf.
- Das Gewächshaus muss von 2 Personen zusammengebaut werden.
- Die Plastiktüten und Kleinteile sollten außerhalb der Reichweite von Kindern aufbewahrt werden. Halten Sie die Kinder vom Montagebereich fern.
- Aluminium ist ein elektrisch leitfähiges Metall, halten Sie die Aluminiumprofile von allen elektrischen Quellen fern.
- Wärmeerzeugenden Geräte (Grill, Brenner, . . .) dürfen im Gewächshaus nicht gelagert werden.
- Das Gewächshaus muss auf einem horizontalen und ebenen, nicht dem Wind ausgesetzten Boden aufgestellt und befestigt werden.
- Stellen Sie sicher, dass es keine Netze (Wasser, Strom oder Gas) unter dem Installationsort gibt.
- Achtung, nicht auf das Dach steigen: Sturz- und schwere Verletzungsgefahr.
- Bei starkem Schneefall den Schnee nicht auf dem Dach ansammeln lassen.

PFLEGEHINWEISE

- Verwenden Sie zur Reinigung Ihres Gewächshauses klares Seifenwasser.
- Verwenden Sie kein Aceton, Scheuermittel oder andere Reinigungsmittel zum Reinigen der Platten.
- Regelmäßig die Türschiene schmieren.
- Räumen Sie das Dach frei von Schnee und Laub.



KUNDENSERVICE

kontakt@gewaechshaus-lams.com



ASSEMBLY INSTRUCTIONS

IMPORTANT

- Please read these instructions carefully before starting to assemble the greenhouse.
- Please ensure that all the components mentioned in this instruction are present in the box and check the quantities.
- Please follow the steps in the order indicated by the manual.
- Please keep this assembly instruction in a safe place for future reference.

SAFETY WARNINGS

- Please wear gloves, shoes and safety goggles when assembling the greenhouse.
- Follow the safety instructions of the tools you use for this assembly.
- In case of bad weather (rain, wind, thunderstorm, ...), do not set up your greenhouse.
- The greenhouse must be assembled by 2 people.
- Plastic bags and small components should be kept out of reach of children. Keep children away from the assembling area.
- Aluminium is a metal with electrical conductivity, keep aluminium profiles away from any electrical source.
- Not all heat-producing appliances (barbecue, torch, ...) can be stored in the greenhouse.
- The greenhouse must be positioned and fixed on a horizontal and even ground, not exposed to wind.
- Check the absence of networks (water, electricity, gas) underneath the installation site of the greenhouse.
- Beware, do not climb on the roof: risk of fall and serious injuries.
- In case of heavy snowfall, do not allow snow to accumulate on the roof.

MAINTENANCE TIPS

- To clean your greenhouse, use clear soapy water.
- Do not use acetone, abrasive cleaners or other special detergents to clean the panels.
- Grease the door rail regularly.
- Clear the roof of snow and leaves.



CUSTOMER SERVICE

Website : www.sav-doviris.com

SOMMAIRE - INHALTSVERZEICHNIS - CONTENTS

- 1** **Module de base 4,90 m² - pages 6 à 28**
Basismodul 4,90 m² - Seiten 6 bis 28
Basic modul 4,90 m² - pages 6 to 28

- 2** **Module de base 4,90 m² et extension 2,40 m² - pages 29 à 47**
Basismodul 4,90 m² und Erweiterung 2,40 m² - Seiten 29 bis 47
Basic modul 4,90 m² and extension 2,40 m² - pages 29 to 47

SERRE - GEWÄCHSHAUS - GREENHOUSE

ALLIUM 4,90 M²

RÉFÉRENCES - ARTIKELNUMMERN - CODES :

- ALUMINIUM : 788692
- RAL 6009 : 788687
- RAL 7016 : 795275

ALLIUM 2,40 M²

RÉFÉRENCES - ARTIKELNUMMERN - CODES :

- ALUMINIUM : 794599
- RAL 6009 : 795235
- RAL 7016 : 795236











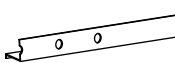

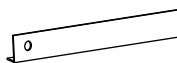
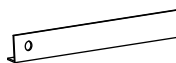
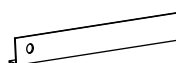
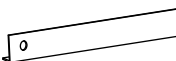



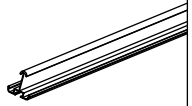
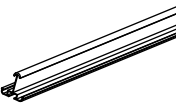

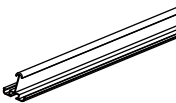
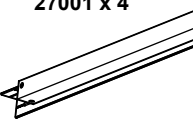
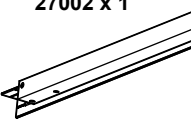
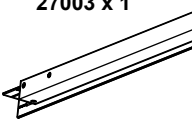
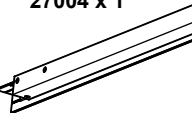
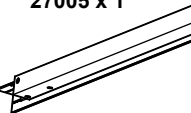

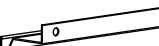

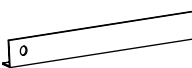



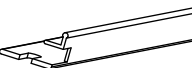

NUMÉRO DE TRAÇABILITÉ - RÜCKVERFOLGBARKEITSNUMMER - TRACEABILITY NUMBER

2021.10

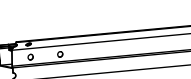

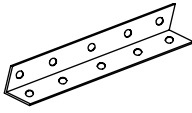
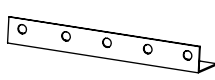
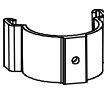
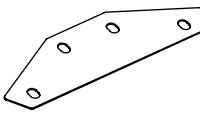
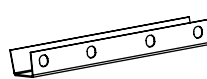
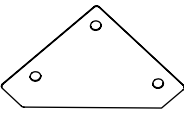
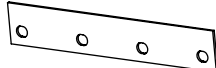
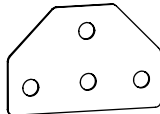
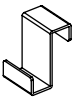
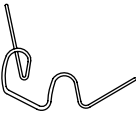

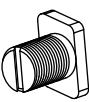
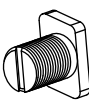
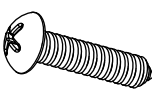



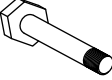

NOMENCLATURE - STÜCKLISTE - BILL OF MATERIALS

Colis - Paket - Parcel

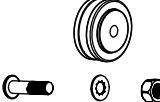
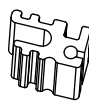

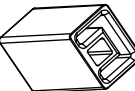
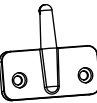
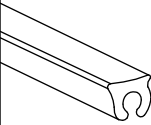

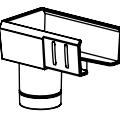

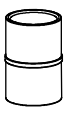
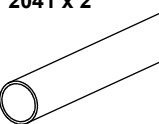
1/2

PROFILÉS ALUMINIUM - ALUMINIUMPROFILE - ALUMINIUM PROFILES					
01001 x 2  L:1241 mm	01002 x 2  L:1241 mm	01003 x 1  L:1862 mm	08001 x 4  L:1657 mm	08002 x 4  L:1302 mm	08003 x 4  L:1623.5 mm
08004 x 1  L:1854 mm	08005 x 2  L:600 mm	10001 x 1  L:1257 mm	15001 x 1  L:270 mm	18001 x 1  L:612 mm	25001 x 6  L:1133 mm
25002 x 6  L:1214 mm	25003 x 1  L:1666.5 mm	25004 x 1  L:1666.5 mm	27001 x 4  L:1214 mm	27002 x 1  L:1156 mm	27003 x 1  L:1156 mm
27004 x 1  L:1156 mm	27005 x 1  L:1156 mm	29001 x 1  L:1650 mm	29002 x 1  L:1650 mm	30001 x 1  L:1862 mm	32001 x 1  L:628 mm
33001 x 1  L:393 mm	34001 x 2  L:1612 mm	35001 x 1  L:621 mm	36001 x 1  L:621 mm	37001 x 2  L:621 mm	38001 x 2  L:1241 mm
39001 x 1  L:634 mm	40001 x 1  L:602 mm	41001 x 2  L:518 mm	42001 x 1  L:602 mm	43001 x 2  L:1241 mm	43002 x 2  L:1241 mm
45001 x 1  L:400 mm	46001 x 2  L:250 mm	58001 x 4 			
PETITS COMPOSANTS - KLEINTEILE - SMALL COMPONENTS					
W001 x 4 	W002 x 2 	W003 x 4 	W004 x 2 	W005 x 2 	W006 x 52 
W007 x 204 	1001 x 146  M6	1002 x 104  M6 x 12 mm	1003 x 23  M6 x 8 mm	1004 x 16  M3.5 x 16 mm	1005 x 10  M3.5 x 6 mm

NOMENCLATURE - STÜCKLISTE - BILL OF MATERIALS

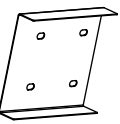
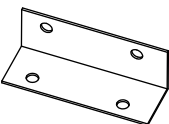
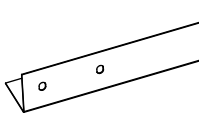
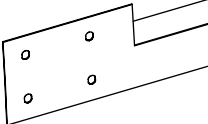
1006 x 1  M6 x 35 mm	1011 x 16  M6 x 14 mm	1012 x 2  M6 x 5 mm	1015 x 2  M6	2001 x 2 	2002 x 2 
2003 x 2 	2004 x 1 	2005 x 2 	2006 x 60 m 	2009 x 1 	2010 x 2 
2022 x 2 	2023 x 2 	2028 x 2 	2032 x 2 	2041 x 2  L: 1120 mm	

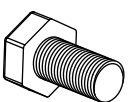





BASE ET VISSERIE - FUNDAMENTRAHMEN UND SCHRAUBEN - GREENHOUSE BASE AND SCREWS

D001 x 2  1922 x 125 x 30 mm	D002 x 4  1272 x 125 x 30 mm	D003 x 2 	D004 x 4 	D005 x 4 	D022 x 2 
W008 x 16 	1008 x 24 	1009 x 24  M6 x 12 mm	1010 x 24  M6		

Colis - Paket - Parcel

2/2

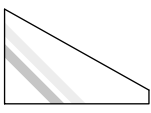

VERRES - GLÄSER - GLAZING

1 x 36  610 x 610 mm	2 x 7  610 x 544 mm	3 x 1  610 x 467 mm	4 x 1  610 x 229mm	5 x 1  600 x 544 mm	6 x 4  610 x 464/38 mm	7 x 2  610 x 20/234/20 mm
--	---	---	--	--	--	---

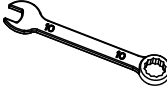
OUTILS INCLUS VORHANDENES WERKZEUG TOOLS INCLUDED

 M6/10 mm	 M6/10 mm
---	---

NON INCLUS NICHT VORHANDEN NOT INCLUDED

	 5 m
---	--

MONTAGE BASE - MONTAGE FUNDAMENTRAHMEN - BASE ASSEMBLING

Module de base
Basismodul
Basic module

Il est impératif que la base soit montée de niveau.



Es ist zwingend erforderlich, dass der Fundamentrahmen auf einem ebenen Untergrund montiert wird.

It is imperative that the greenhouse base is leveled.

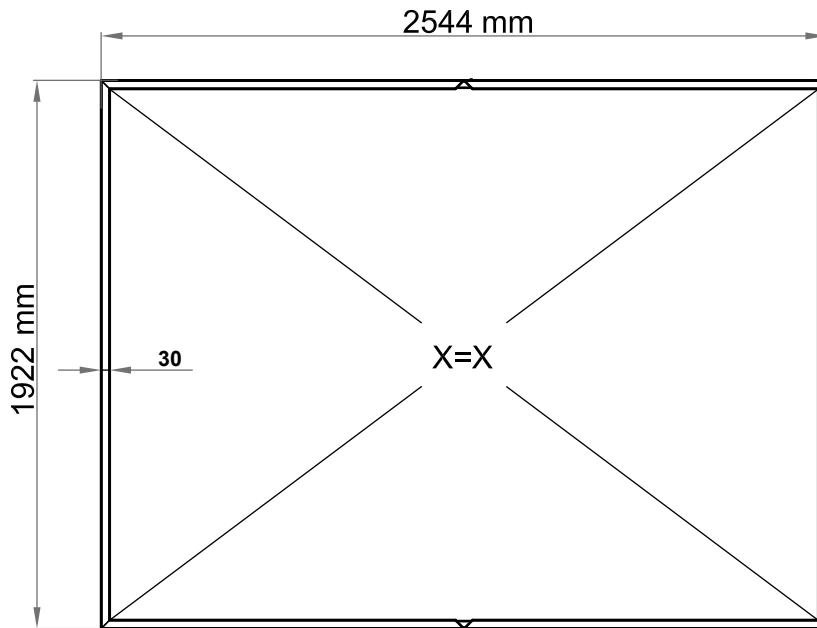

Plots béton / Punktfundament / Point foundation : D004 + D005 + D022.

Dalle ou pourtour béton / Streifenfundament / Concrete slab or frame : D004.

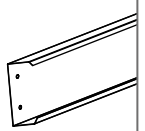
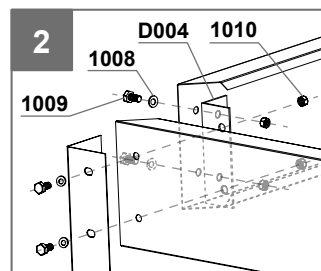
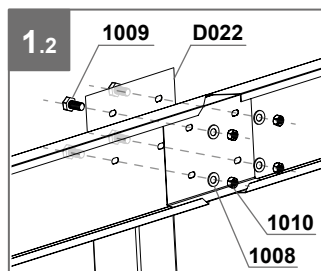
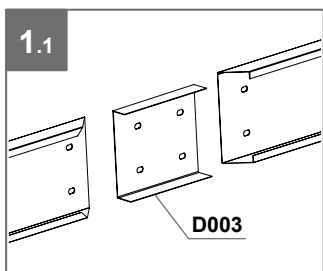
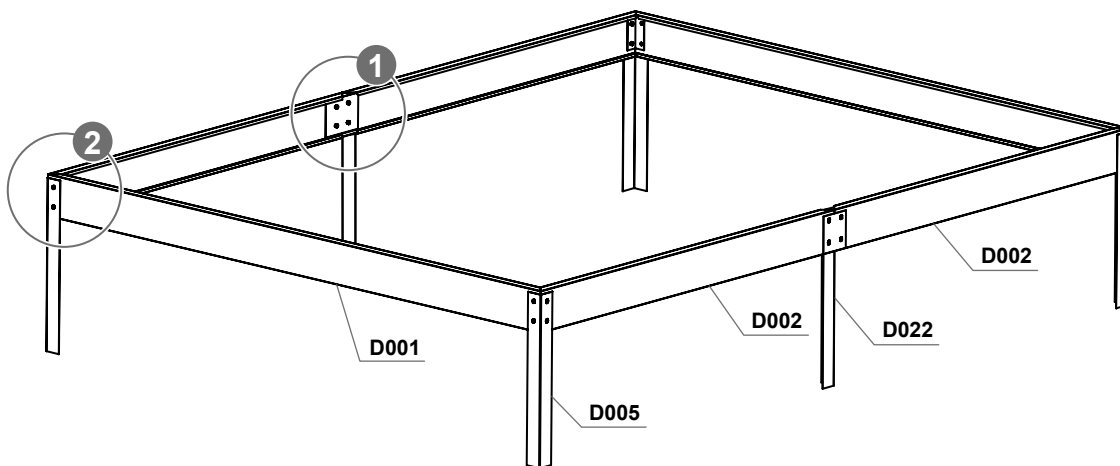

D001 x 2

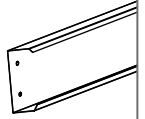

D002 x 4

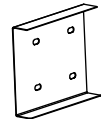

D003 x 2

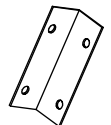

D004 x 4

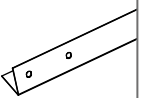

D005 x 4

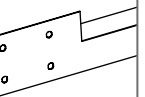

D022 x 2



W008 x 16



1008 x 24



1009 x 24



1010 x 24



FIXATION DE LA BASE AU SOL

FIXATION EN PLEINE TERRE

- Positionner la base à l'endroit voulu, de niveau sur un sol damé.
- Repérer l'emplacement des pattes de scellement suivant le schéma ci-dessous.
- Marquer un carré de 300 x 300 mm autour des pattes de scellement et creuser sur une profondeur de 450 mm.
- Placer la base, la mettre de niveau et remplir les trous de béton.

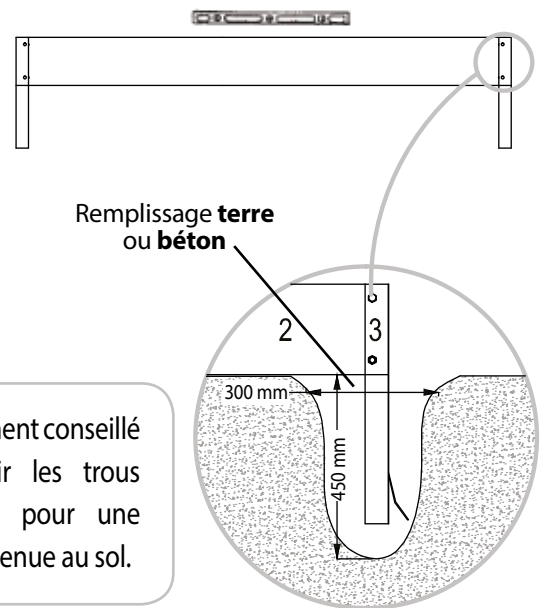
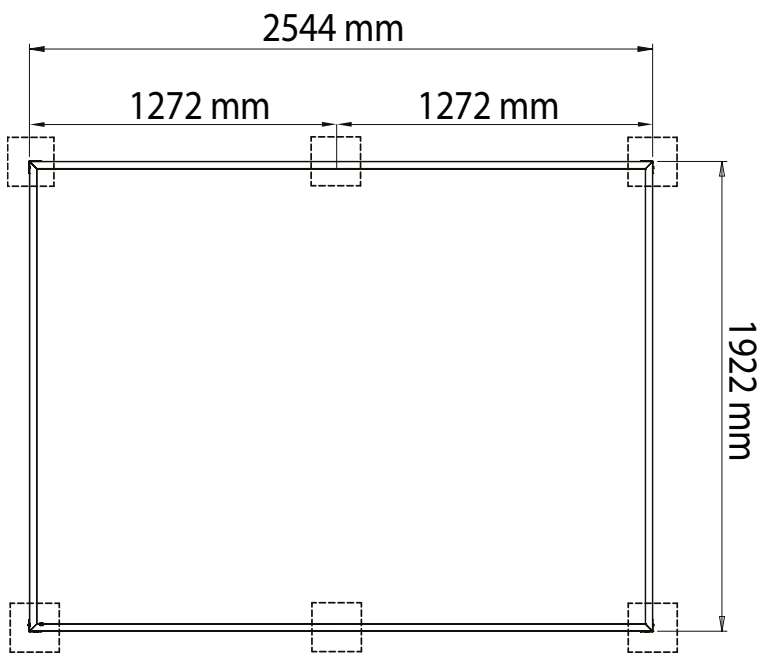

Il est vivement conseillé de remplir les trous de béton pour une meilleure tenue au sol.

OU

FIXATION SUR DALLE BÉTON

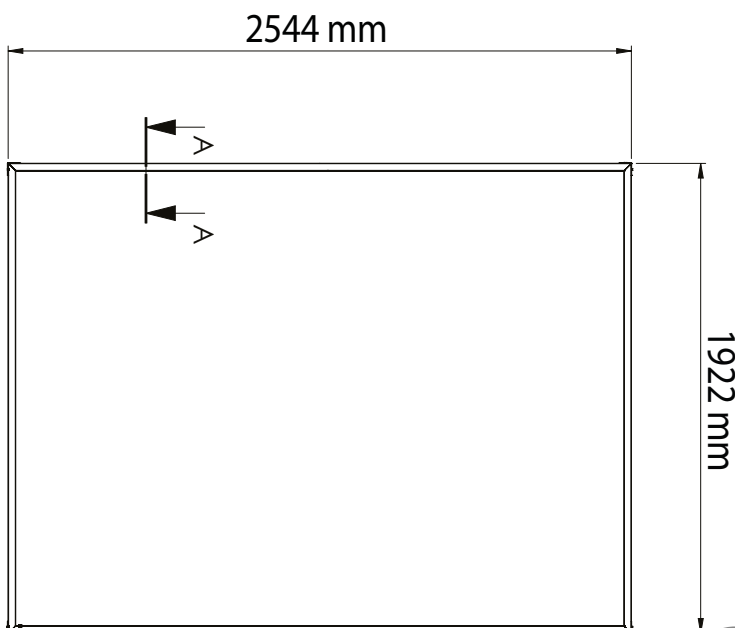

Détail A-A

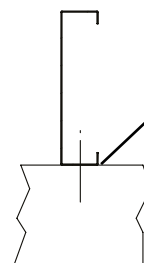

Fixation par chevilles à l'intérieur de la base



Visseries et chevilles de fixation non fournies

Il est laissé à votre libre choix et décision, l'utilisation des fixations adéquats selon les supports que vous décidez d'utiliser (pourtour bois, parpaings, plaques ciment, ...).



BEFESTIGUNG DES FUNDAMENTRAHMENS AM BODEN

BEFESTIGUNG AUF ERDBODEN (Punktfundament)

- Stellen Sie den Fundamentrahmen an der gewünschten Stelle, auf einem ebenen Boden.
- Finden Sie die Stelle der Ankerbeine gemäß dem untenstehenden Schema.
- Markieren Sie ein 300 x 300 mm Quadrat um die Ankerbeine herum und graben Sie 450 mm tief.
- Den Fundamentrahmen platzieren, nivellieren und die Löcher mit Beton füllen.

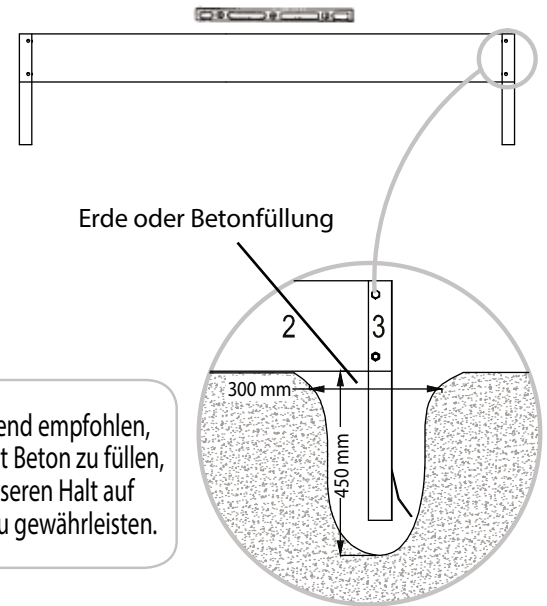
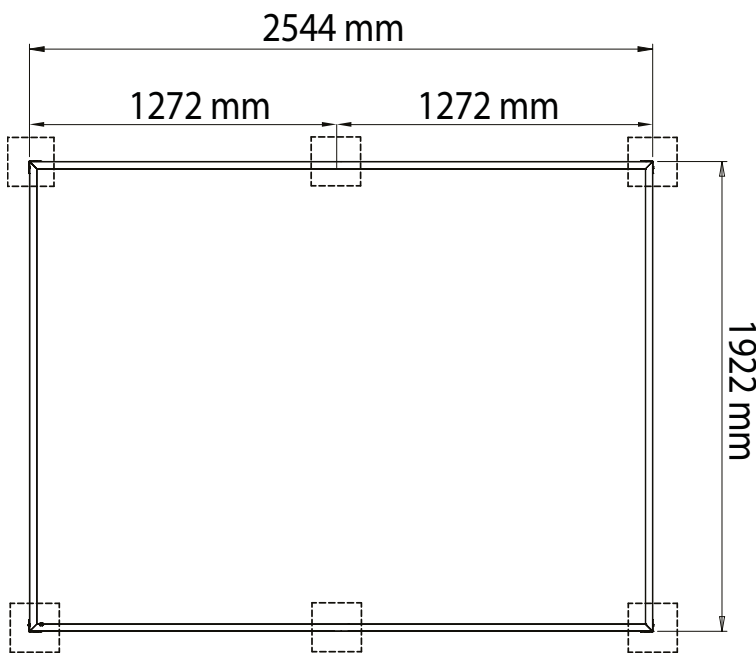

Es wird dringend empfohlen, die Löcher mit Beton zu füllen, um einen besseren Halt auf dem Boden zu gewährleisten.

ODER

BEFESTIGUNG AUF BETONDECKE (Streifenfundament)

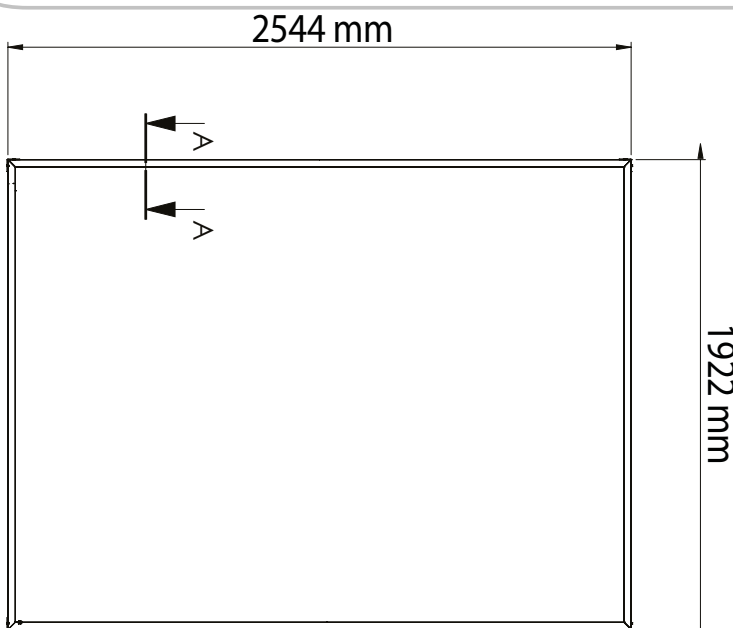

Detail A-A



Es bleibt Ihrer freien Wahl und Entscheidung überlassen, die geeigneten Befestigungsmittel entsprechend der von Ihnen gewählten Träger (Holzumrandung, Bausteine, Zementplatten,...) zu verwenden.



FIXING THE GREENHOUSE BASE TO THE GROUND

FIXING ON SOIL (POINT FOUNDATION)

- Position the greenhouse base in the desired location at a level position on a filled floor.
- Locate the base legs as shown bellow.
- Mark a 300 x 300 mm square around the base legs and dig 450 mm deep.
- Place the greenhouse base, level it and fill the holes with concrete.

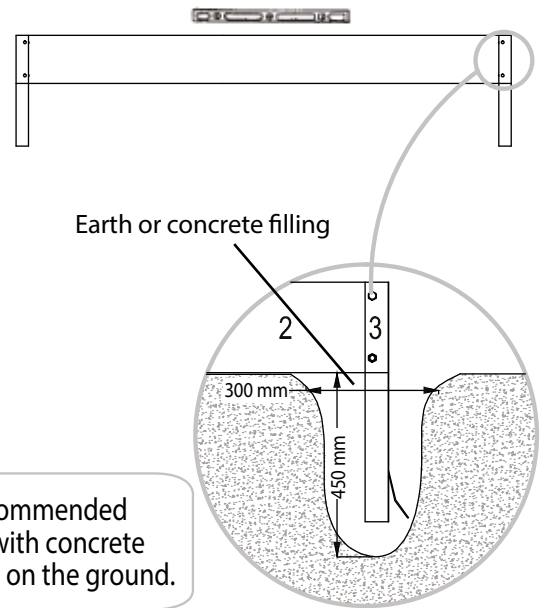
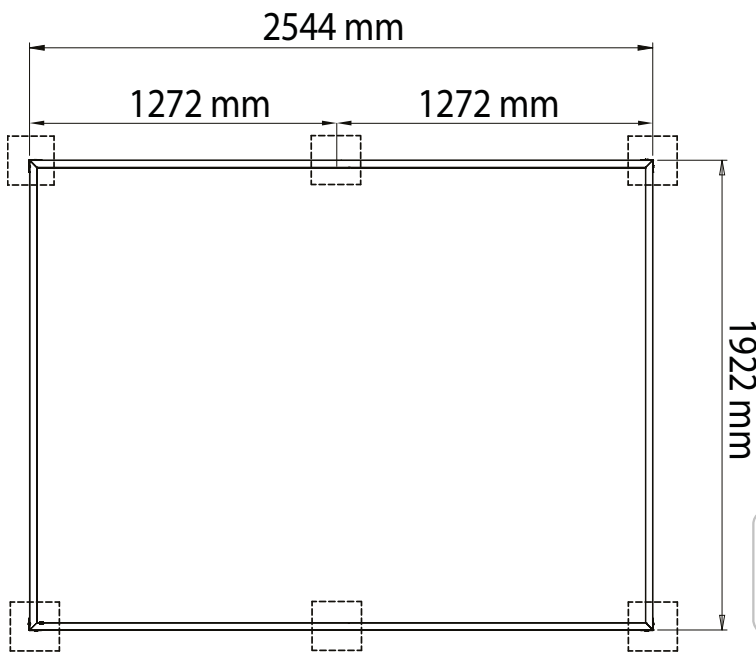

It is strongly recommended to fill the holes with concrete for a better hold on the ground.

OR

FIXING ON CONCRETE SLAB

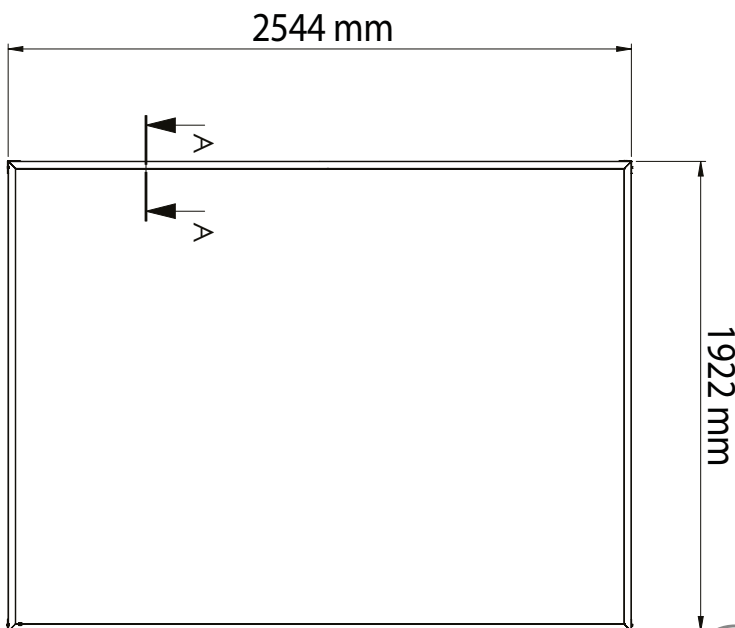

Detail A-A

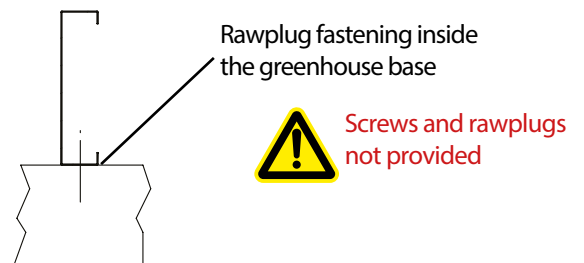

It remains to your free choice and decision to use the suitable fastening means according to the supports you chose (wood border, building stones, cement plates etc.)

VIS 1002 & 1003 - SCHRAUBEN 1002 & 1003 - SCREWS 1002 & 1003

Mise en place des vis 1002 et 1003 dans les rainures en forme de T des profilés aluminium :
Entrez la tête de vis dans la rainure du profilé et tournez à 90° afin qu'elle ne puisse pas sortir du profilé. Assemblez la/les pièce(s) nécessaire(s) et serrez l'écrou.

Verwendung der Schrauben 1002 und 1003 in den t-förmigen Nuten der Aluminiumprofile :
Schraubenkopf in die Profilmutter stecken und diesen um 90° drehen, damit er nicht aus dem Profil herauskommt. Bauen Sie das/die benötigte(n) Einzelteil(e) zusammen und ziehen Sie die Schraubenmuttern an.

Principle of use of screws 1002 and 1003 in the T-shaped grooves of the aluminium profiles :
Enter the screw head into the groove of the profile and turn the screw head at 90° so that it cannot exit the profile. Assemble the required part(s) and tighten the screw nut.

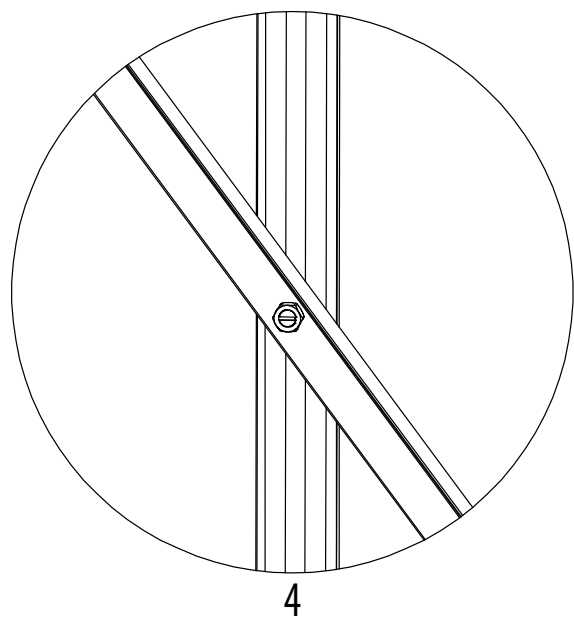
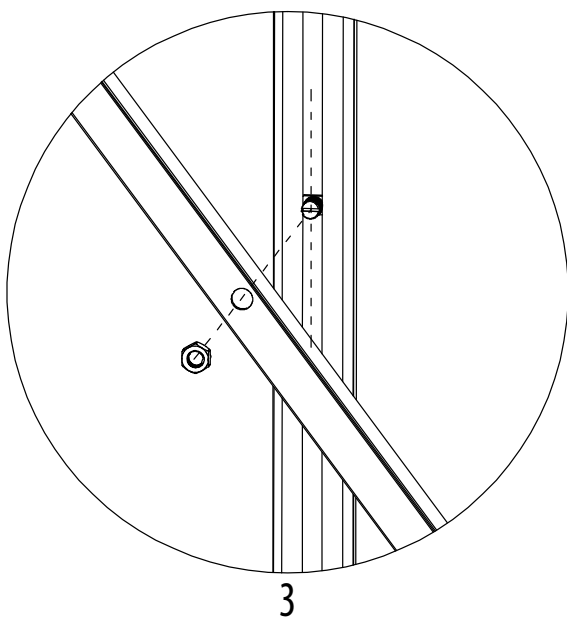
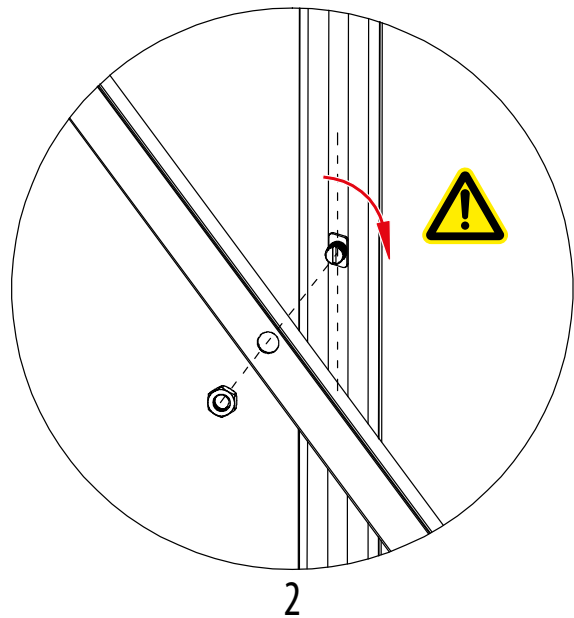
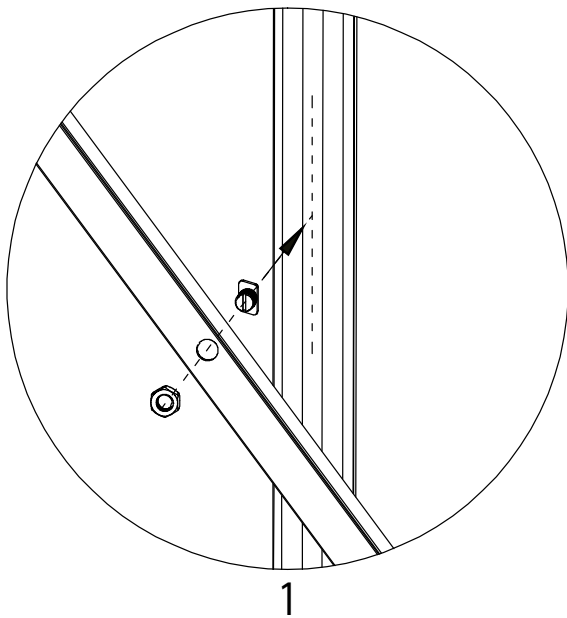

LONG-PAN (CÔTÉ) x2 - SEITENWAND x2 - SIDE WALL x2



Fixation des profilés de vitrage sur la traverse haute.
Befestigung der Verglasungsprofile am oberen Querträger.
Fastening the glazing profiles on the upper crossbeam.

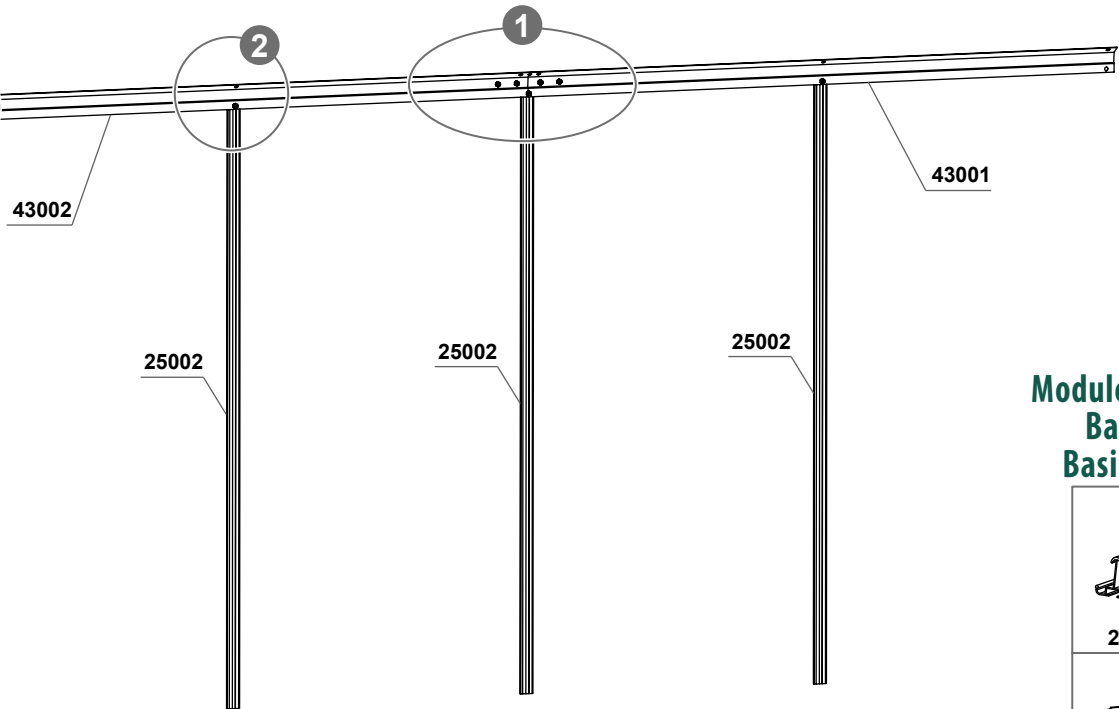
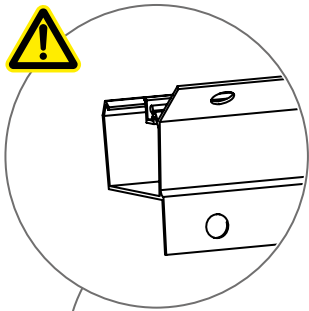

Module de base Basismodul Basic module



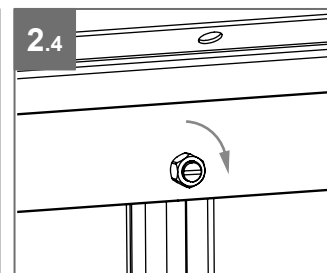
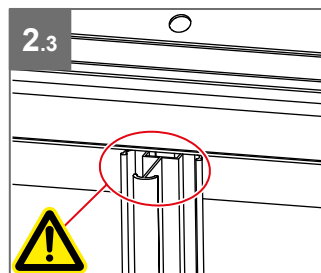
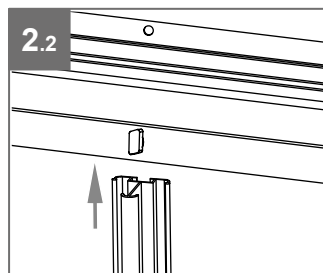
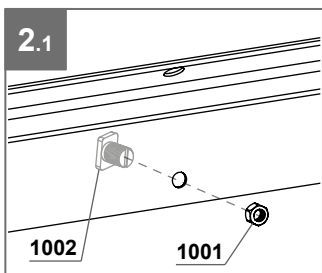
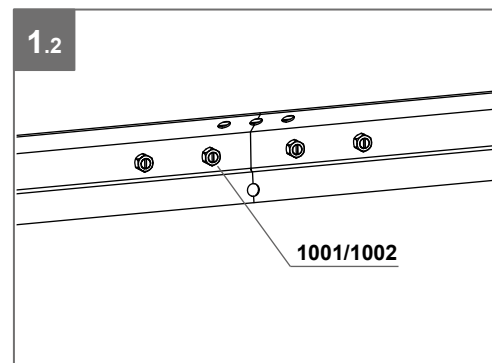
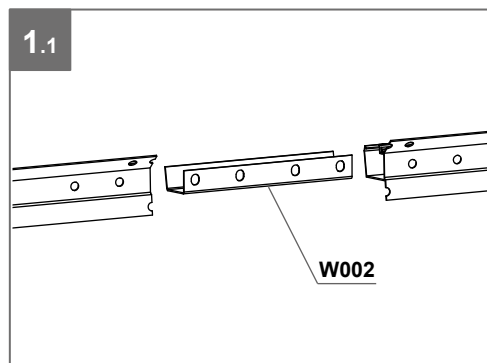

	25002 x 6
	43001 x 2
	43002 x 2
	W002 x 2
	1001 x 14
	1002 x 14

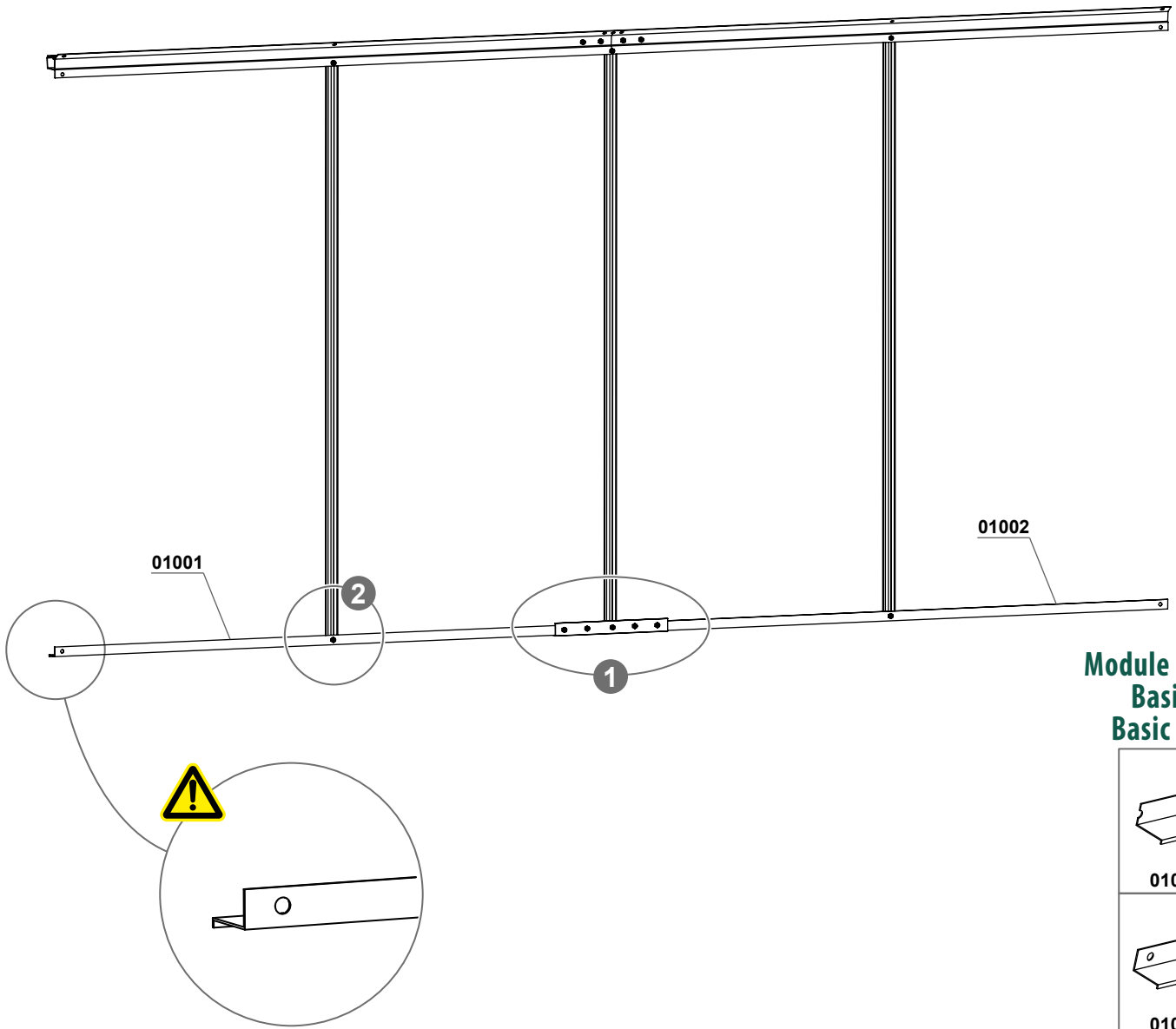

LONG-PAN (CÔTÉ) x2 - SEITENWAND x2 - SIDE WALL x2

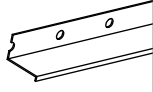
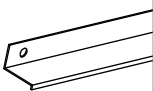
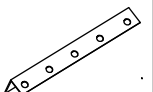

Module de base Basismodul Basic module

- 
01001 x 2
- 
01002 x 2
- 
46001 x 2
- 
1001 x 14
- 
1002 x 6
- 
1011 x 8

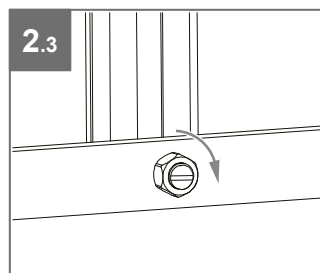
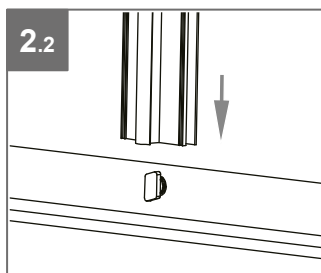
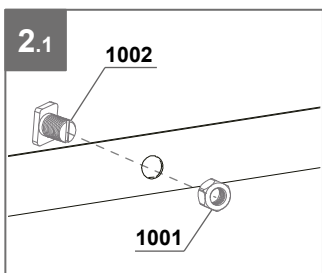
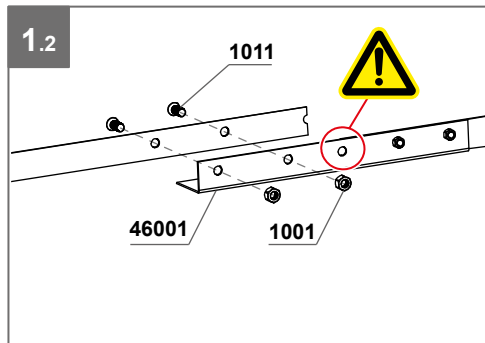
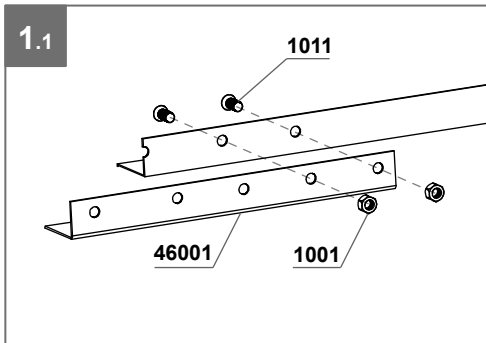

FACE AVANT (AVEC PORTE) - VORDERWAND (MIT TÜR) FRONT WALL (WITH DOOR)

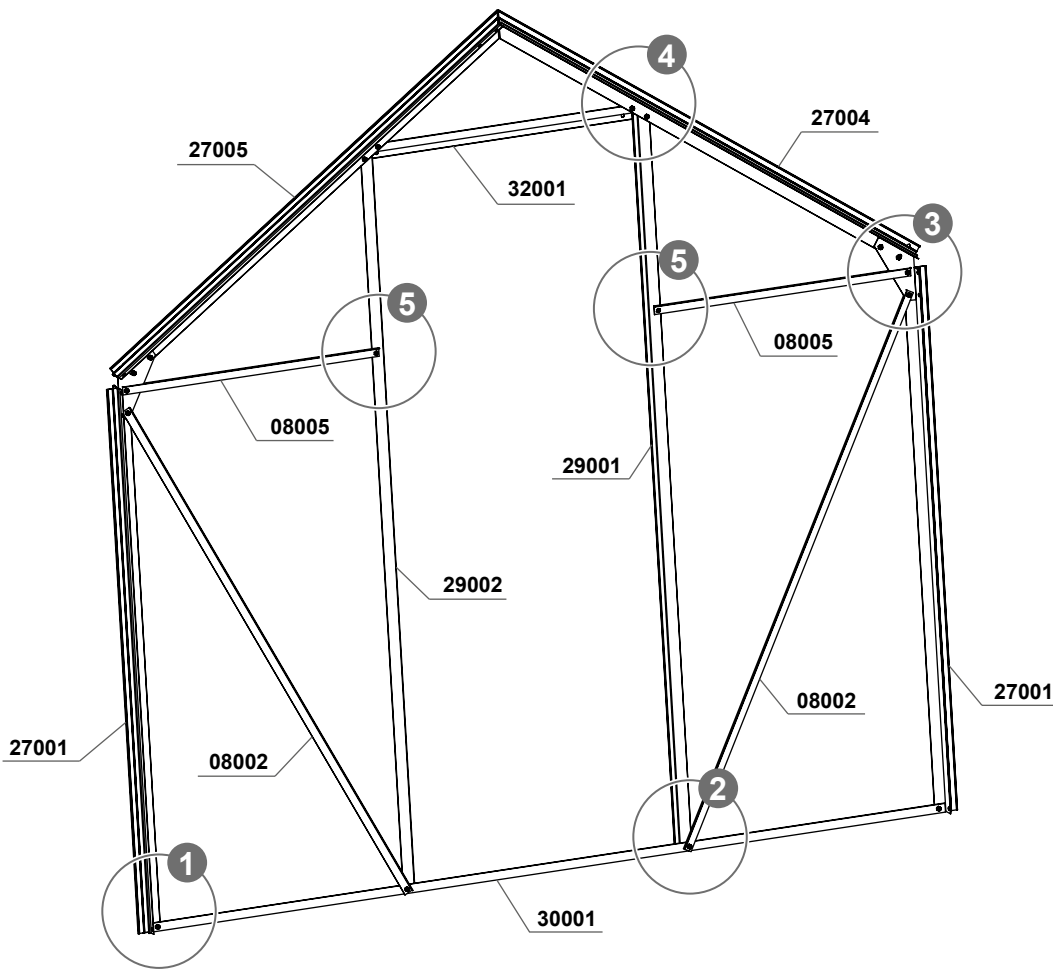

Vue intérieure
Innenansicht - Interior view



Vue intérieure
Innenansicht - Interior view

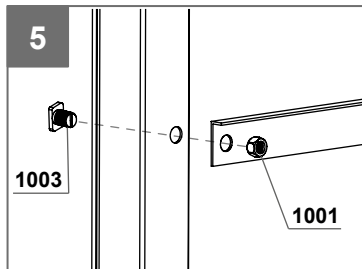
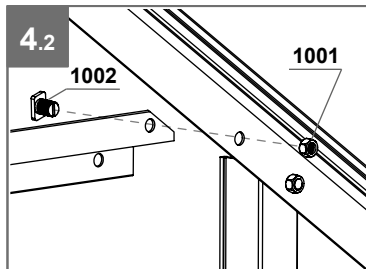
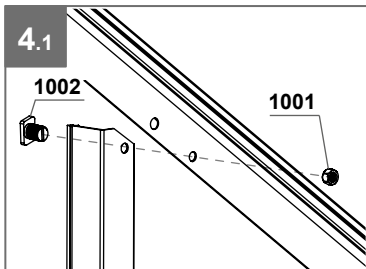
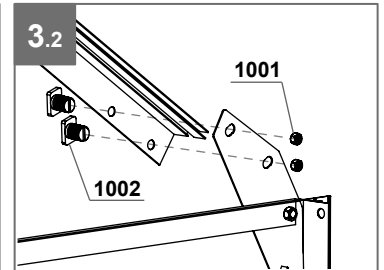
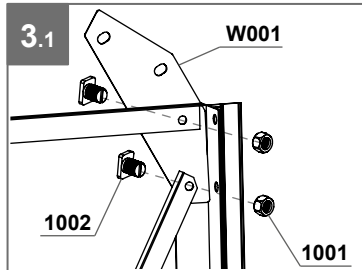
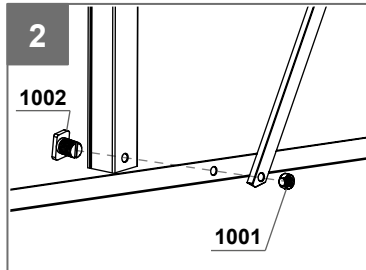
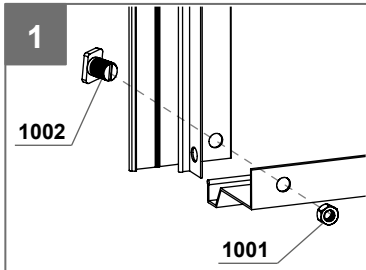

Module de base Basismodul Basic module

27004 x 1	27005 x 1	29001 x 1	29002 x 1	30001 x 1	32001 x 1	W001 x 2	1001 x 18	1002 x 16	1003 x 2

FACE ARRIÈRE (SANS PORTE) - RÜCKWAND (OHNE TÜR) REAR WALL (WITHOUT DOOR)



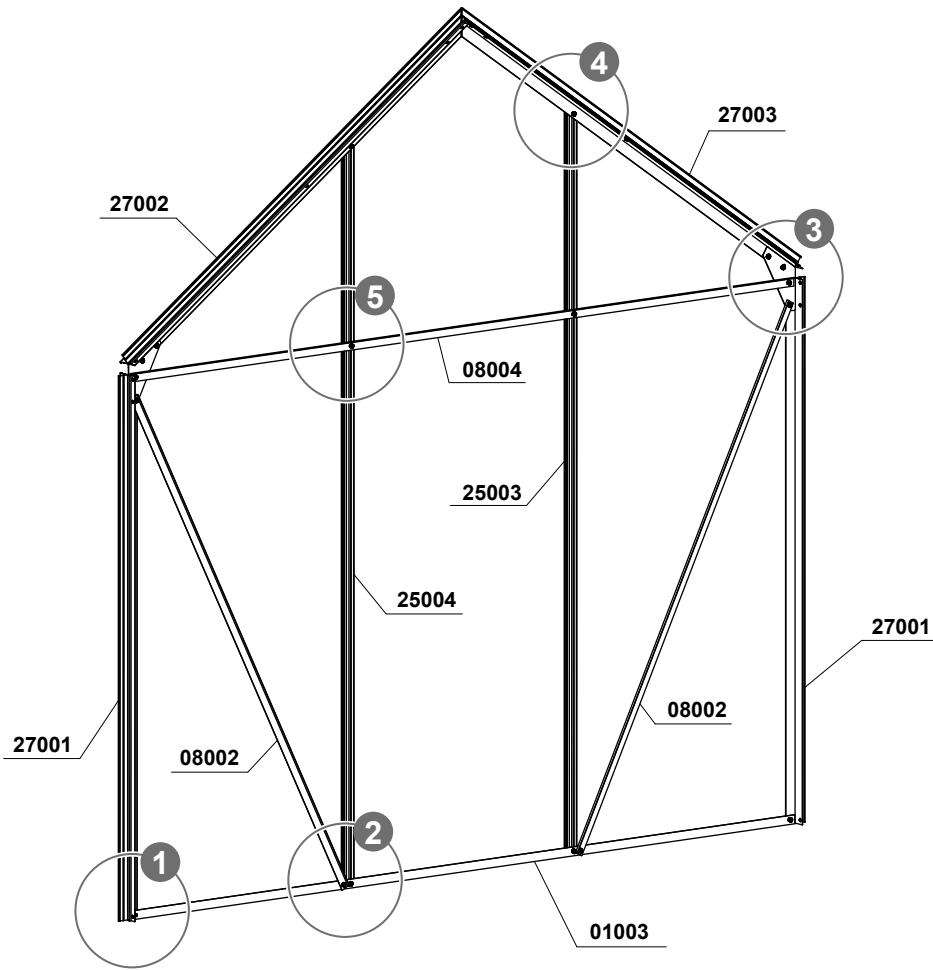





Module de base
Basismodul
Basic module

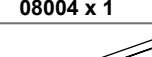
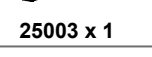

Vue extérieure
Außenansicht
Exterior view

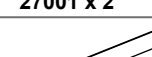
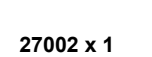

Vue intérieure
Innenansicht
Interior view

-  01003 x 1
-  08002 x 2
-  08004 x 1
-  25003 x 1
-  25004 x 1
-  27001 x 2
-  27002 x 1
-  27003 x 1
-  W001 x 2
-  1001 x 18
-  1002 x 16
-  1003 x 2

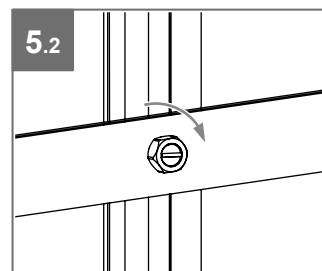
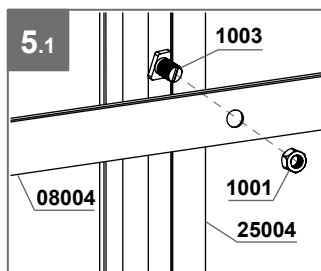
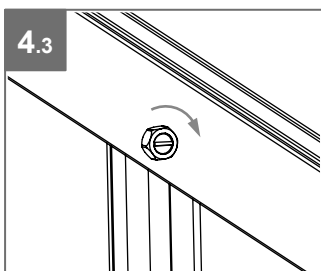
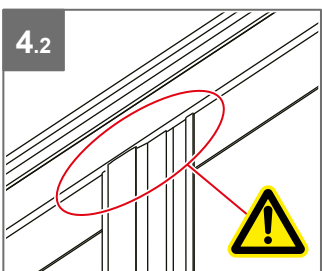
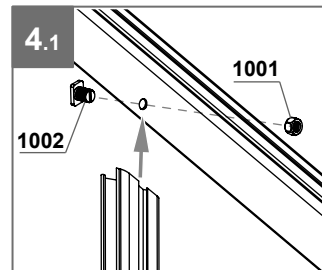
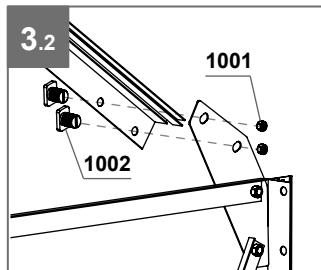
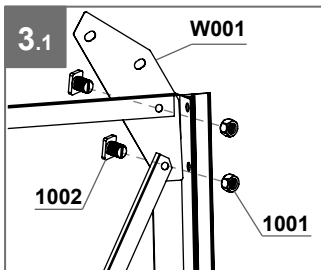
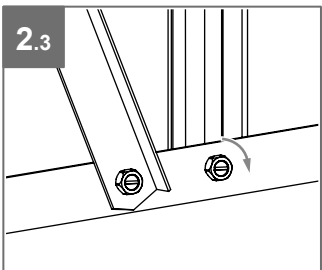
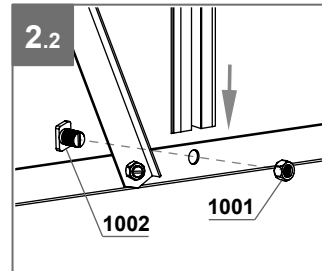
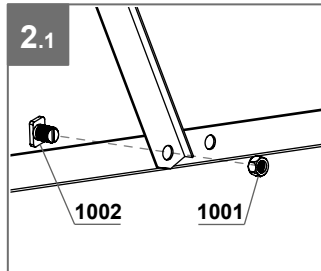
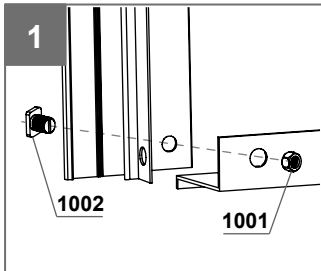

PORTE - TÜR - DOOR

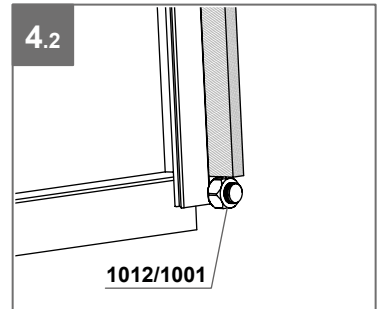
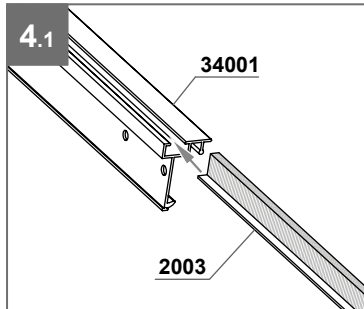
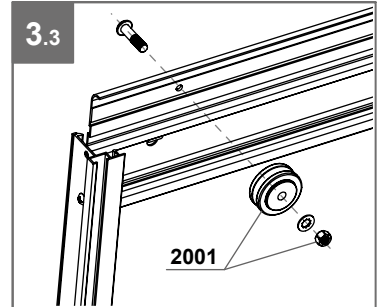
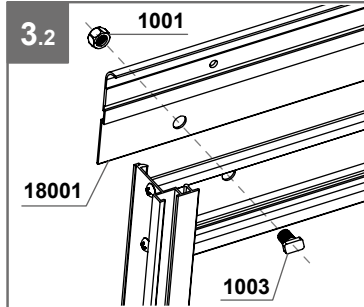
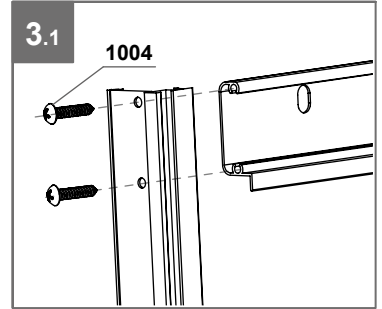
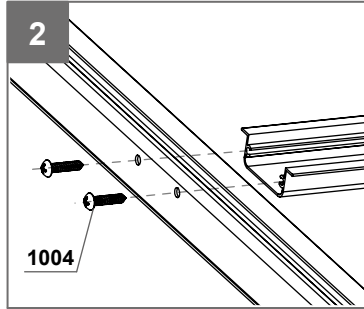
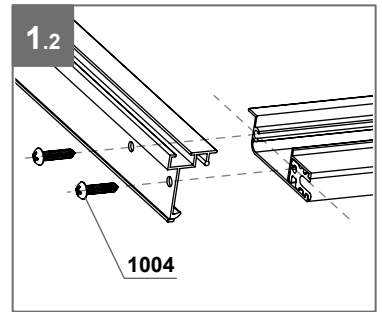
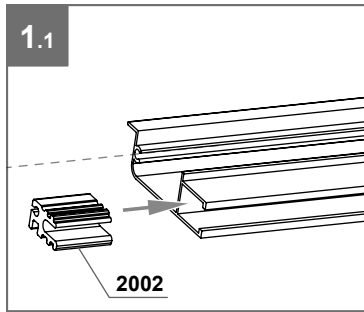
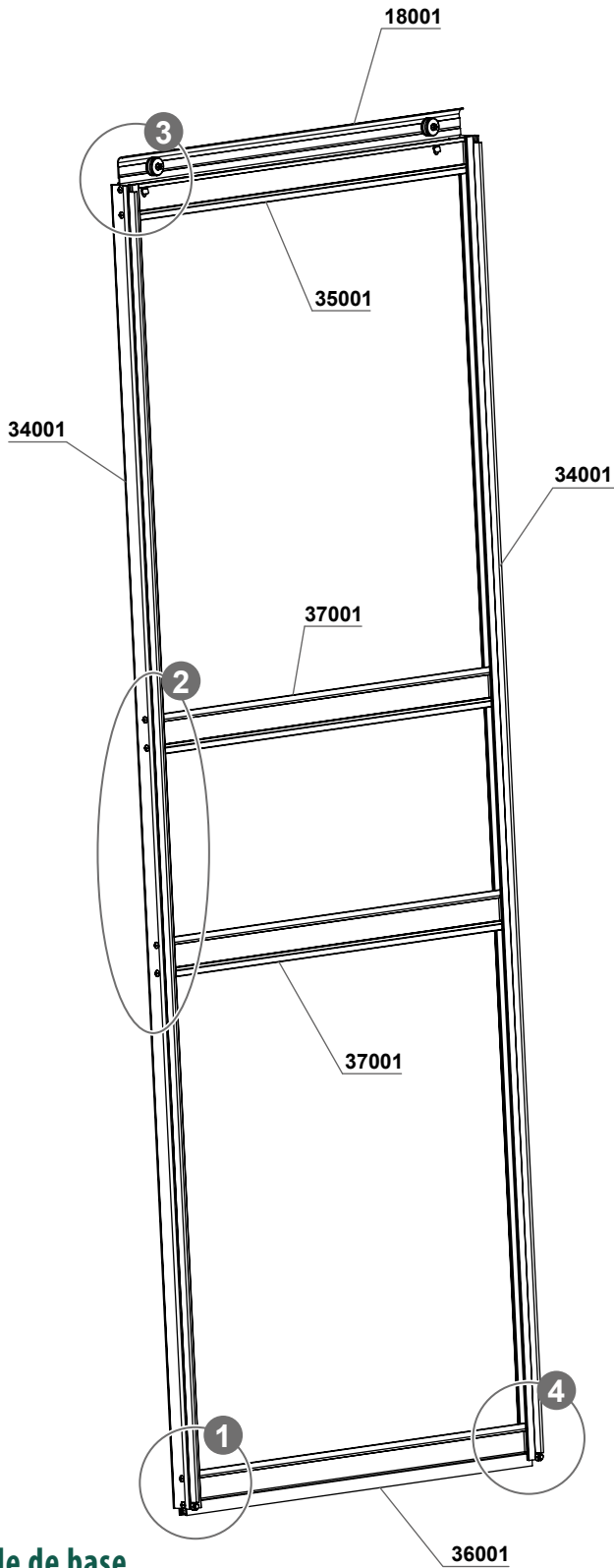

Module de base Basismodul Basic module

36001 x 1	37001 x 2	2001 x 2	2002 x 2	2003 x 2	1001 x 4	1003 x 2	1004 x 16	1012 x 2

LUCARNE - FENSTER - WINDOW

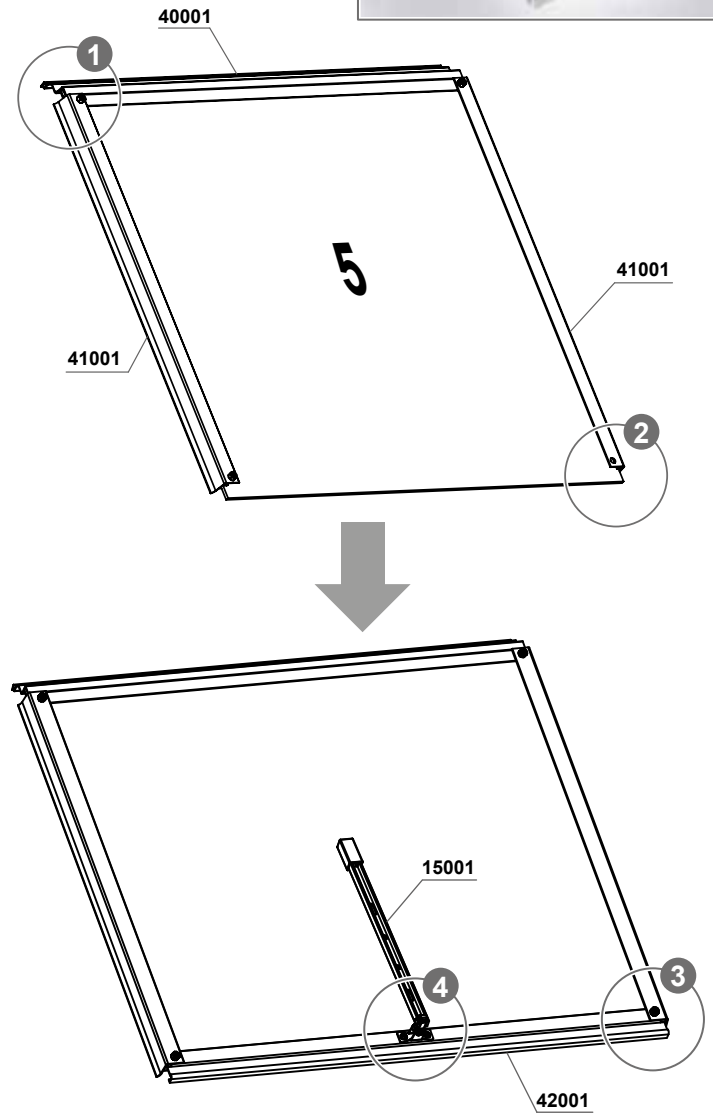
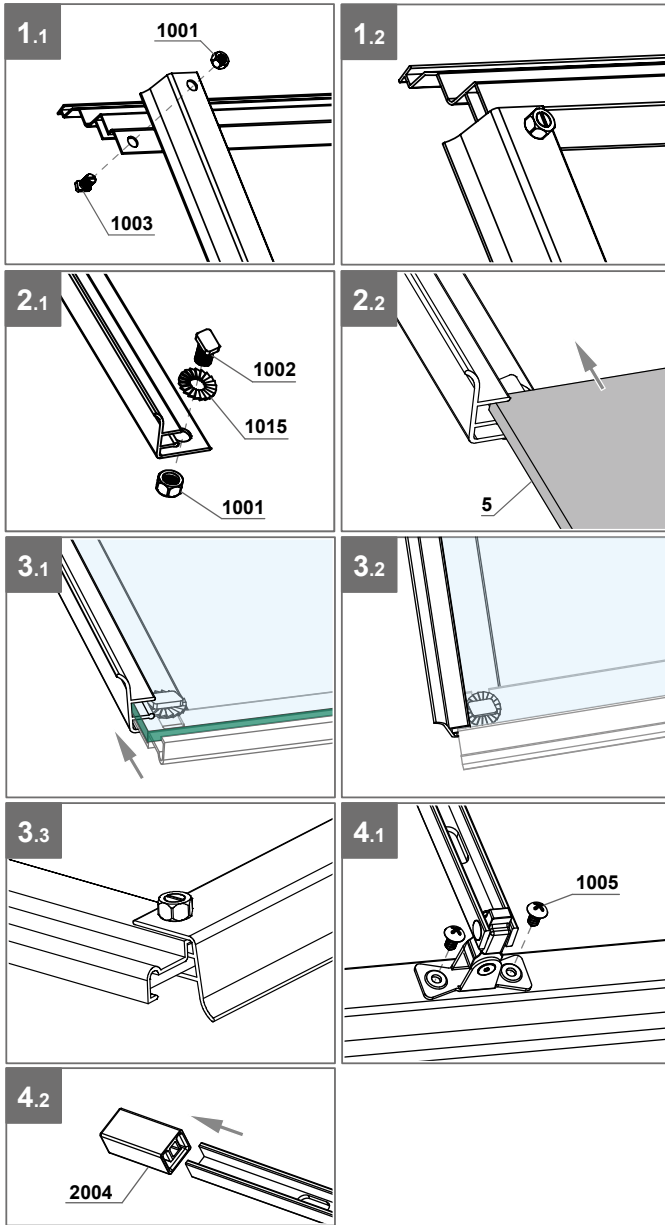

Module de base - Basismodul - Basic module

40001 x 1	41001 x 2	42001 x 1	2004 x 1	1001 x 4	1002 x 2	1003 x 2	1005 x 2	1015 x 2
600 x 544 mm								
5 x 1	15001 x 1							

Module d'extension - Erweiterungsmodul - Extension module

40001 x 1	41001 x 2	42001 x 1	2004 x 1	1001 x 4	1002 x 2	1003 x 2	1005 x 2	1015 x 2

MONTAGE DES PROFILÉS DE TOITURE - MONTAGE DER DACHPROFILE ASSEMBLING THE ROOF PROFILES

Module de base
Basismodul
Basic module

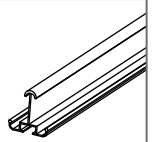
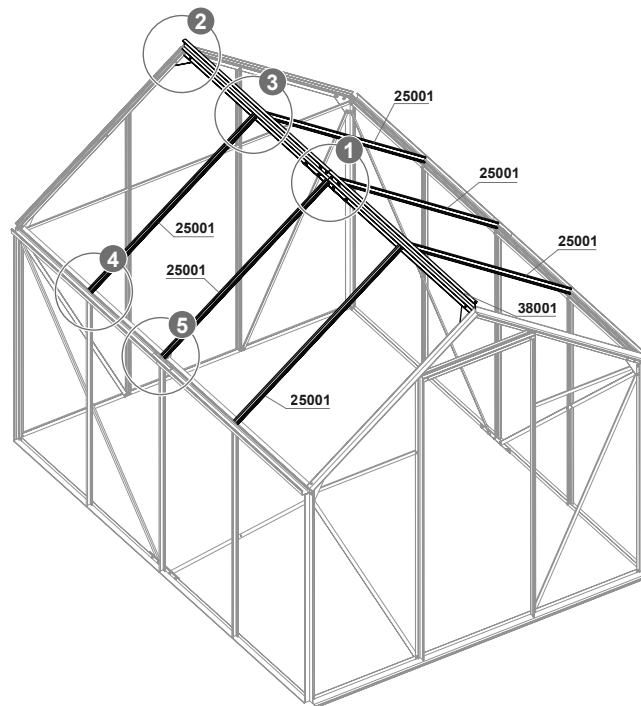

25001 x 6

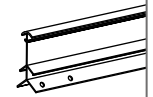

38001 x 2

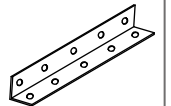

45001 x 1

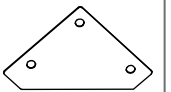

W003 x 4

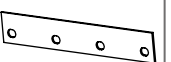

W004 x 2

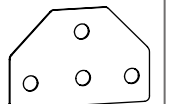

W005 x 2



1001 x 34



1002 x 22



1003 x 4



1011 x 8

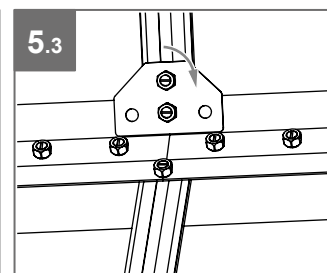
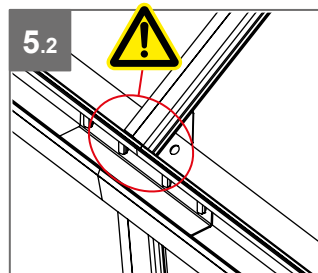
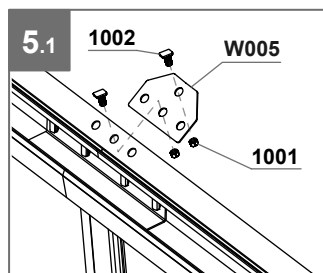
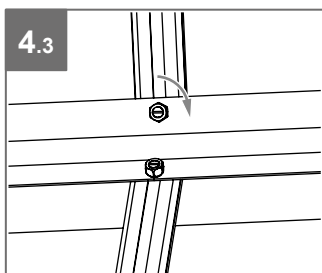
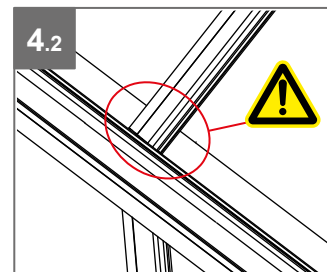
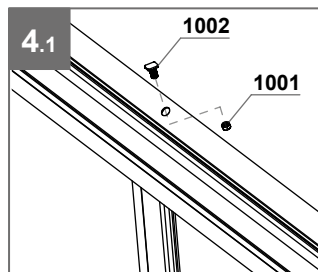
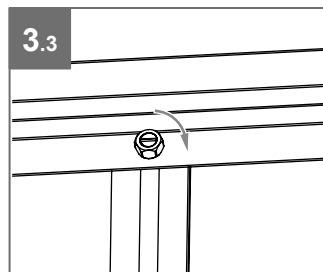
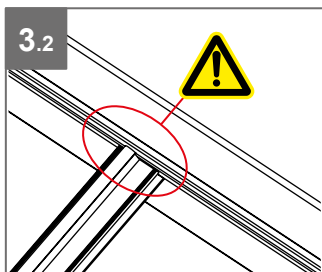
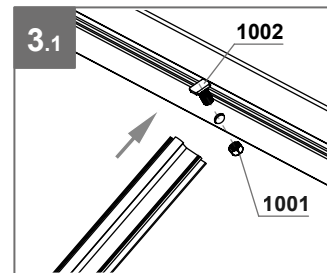
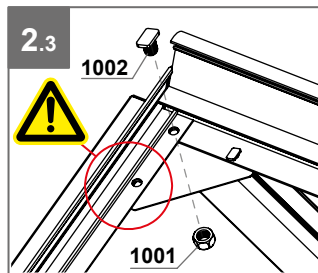
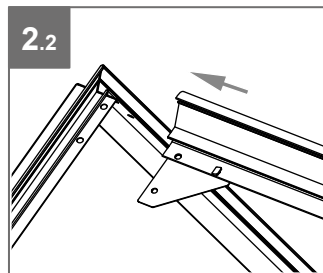
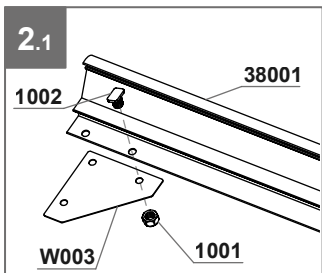
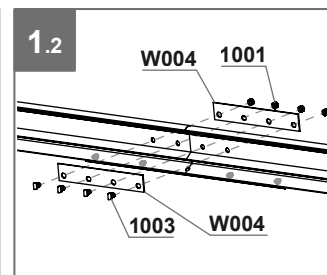
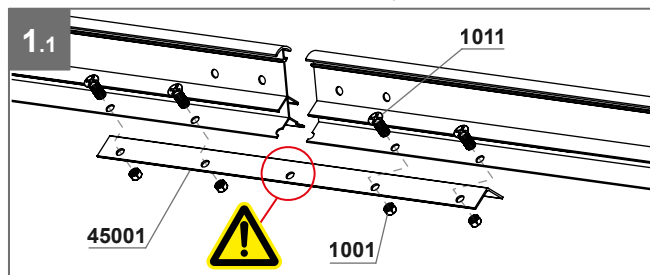

MONTAGE DES TENDEURS ET GOUSSETS SPANNVORRICHTUNG UND VERBINDER WIND BRACES AND GUSSETS

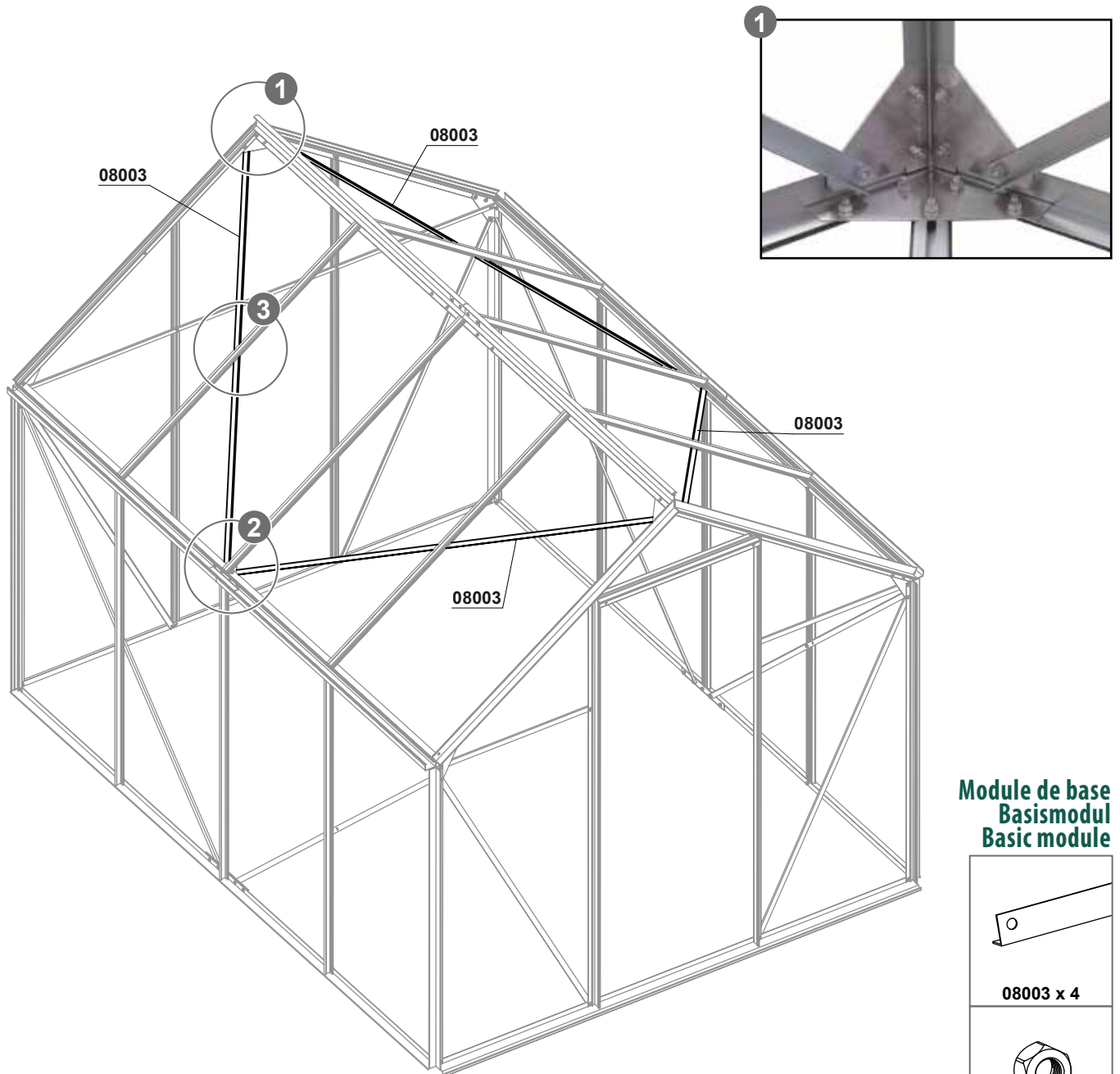

Module de base
Basismodul
Basic module

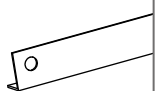

08003 x 4



1001 x 12



1002 x 8



1003 x 4

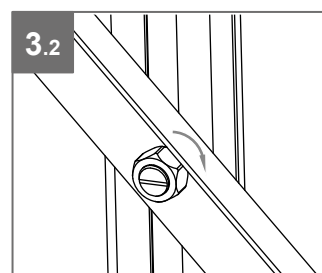
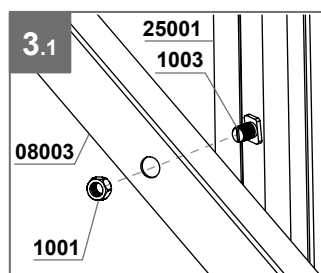
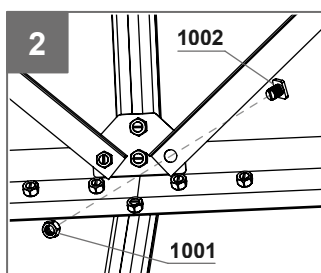
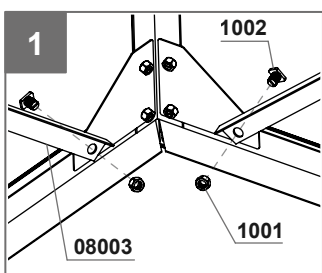

FIXATION DE LA SERRE SUR LA BASE BEFESTIGUNG DES GEWÄCHSHAUSES AM FUNDAMENTRAHMEN FASTENING THE GREENHOUSE ONTO THE GREENHOUSE BASE

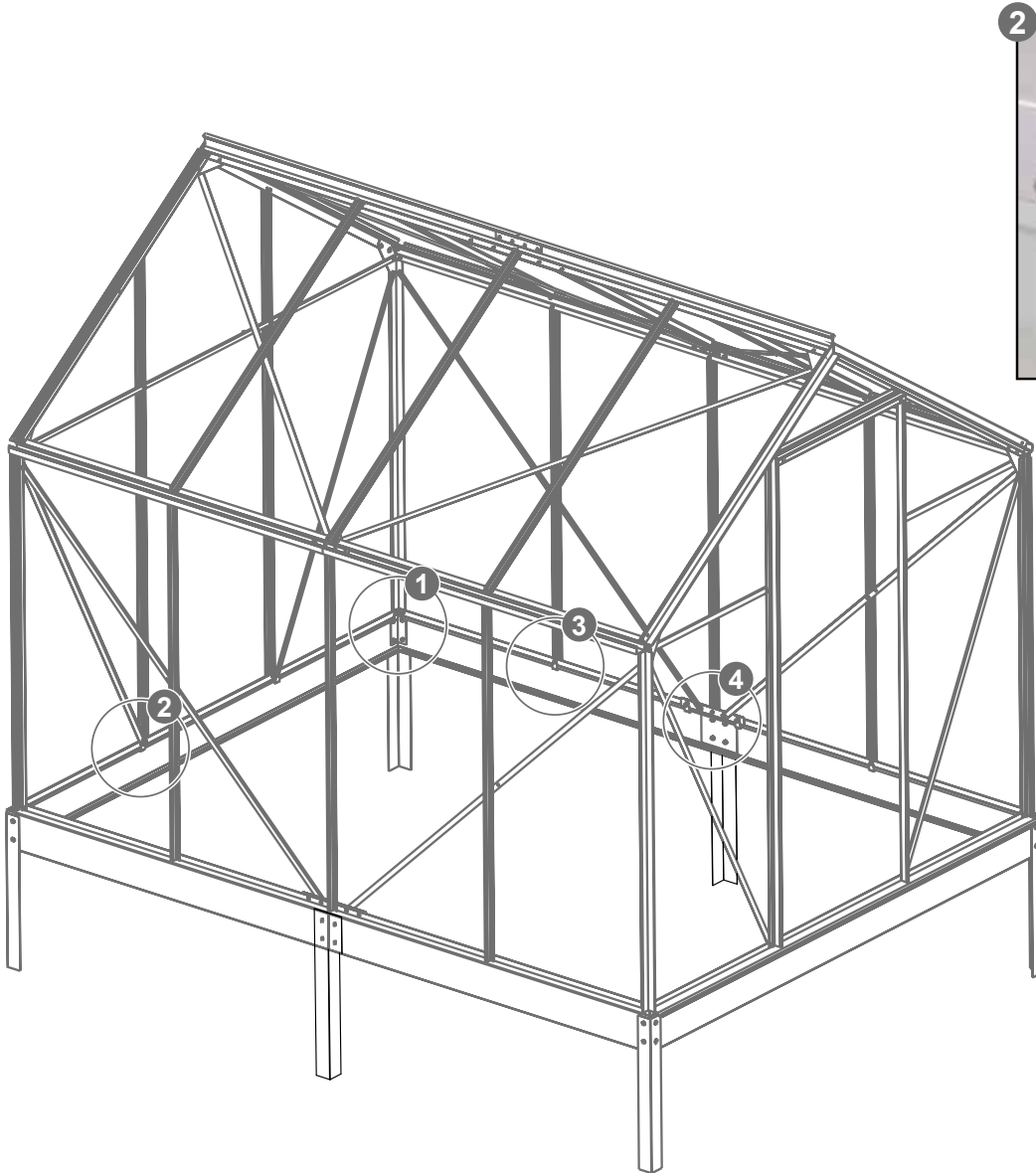

Crochet à positionner
Haken anbringen
Attach hook

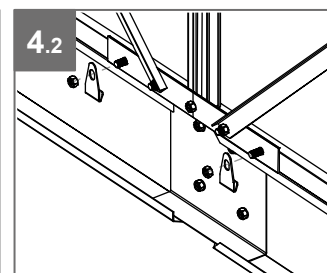
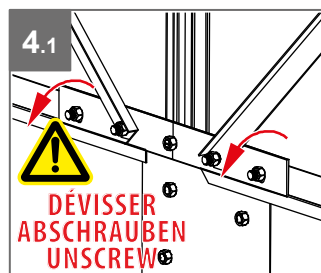
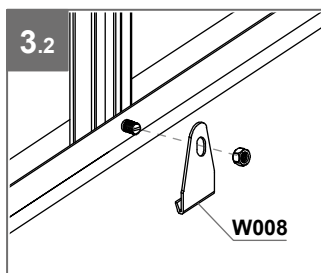
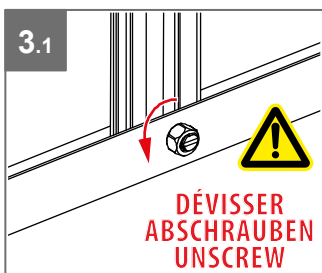
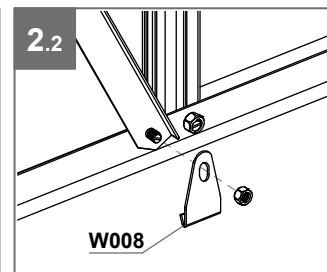
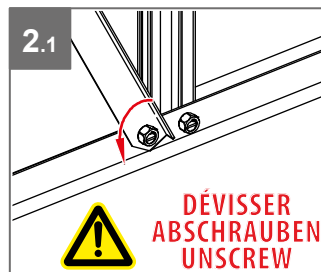
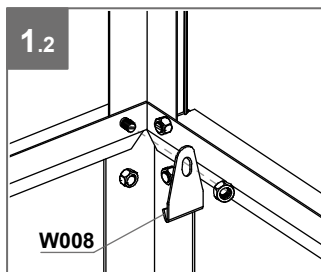
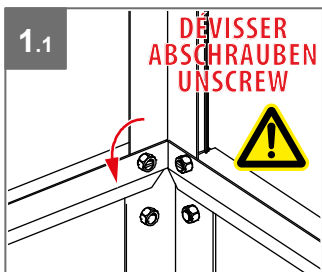

Module de base
Basismodul
Basic module

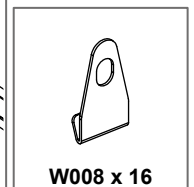

MONTAGE PORTE + RAIL MONTAGE TÜR + SCHIENE ASSEMBLING DOOR + RAIL

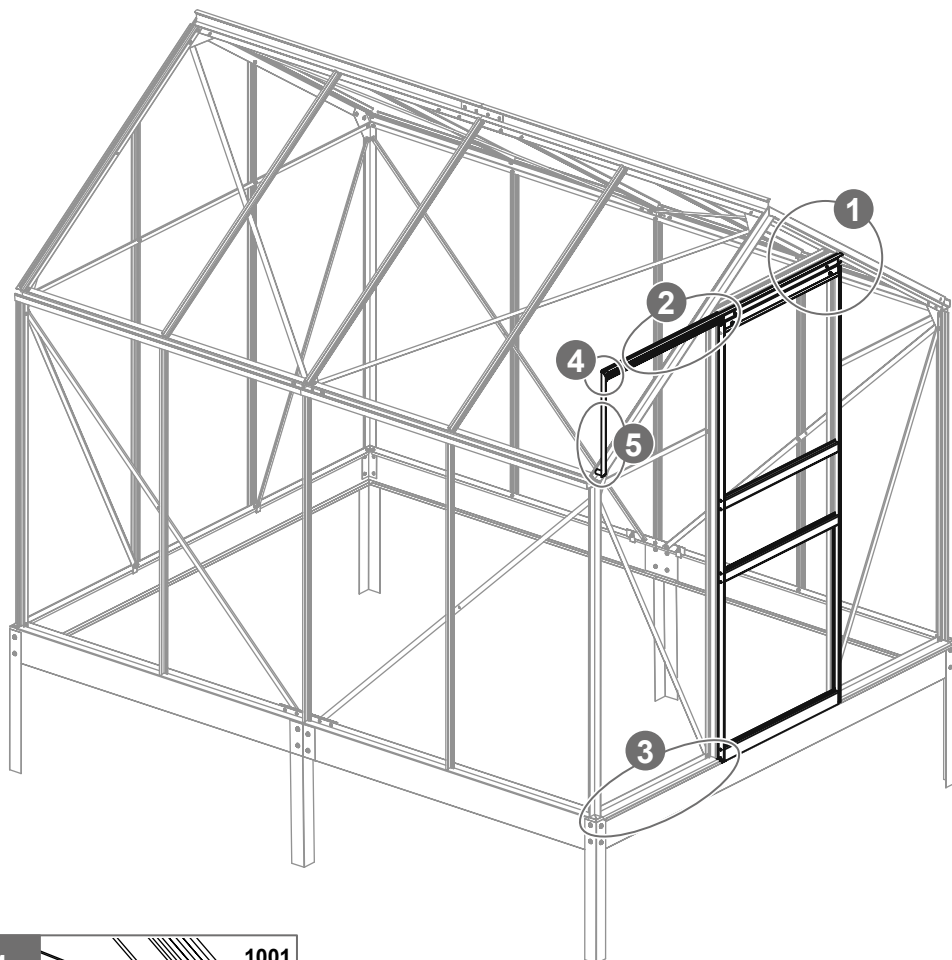

Recommandation : graissage régulier
Empfehlung : regelmäßig schmieren
Recommendation : grease regularly

Module de base Basismodul Basic module

	10001 x 1
	33001 x 1
	2009 x 1
	1001 x 6
	1002 x 2
	1003 x 3
	1006 x 1



Haut de porte
Oberer Türbereich
Upper door area

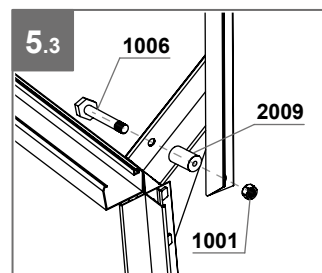
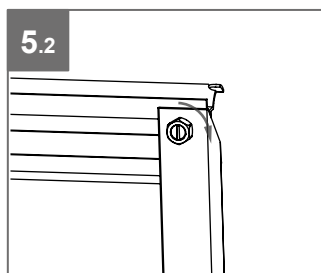
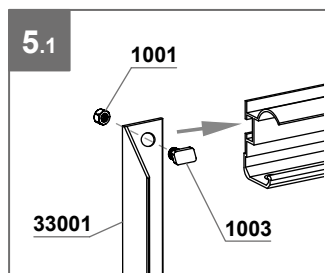
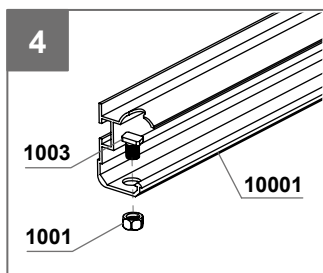
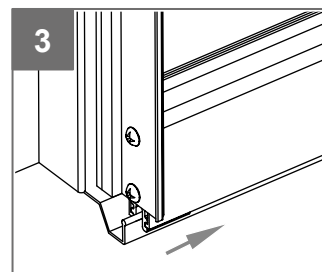
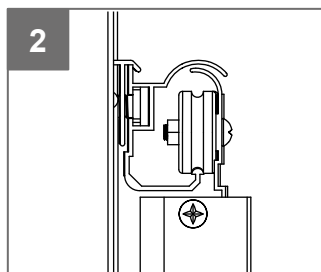
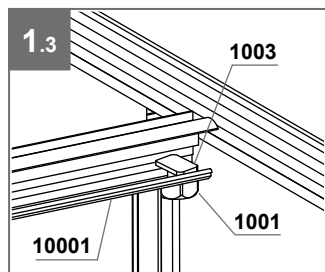
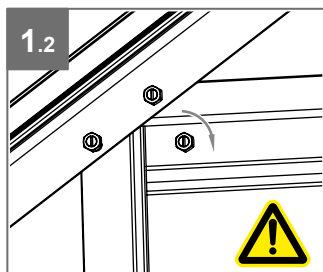
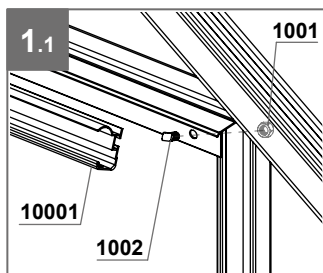

POSE DU JOINT DE VITRAGE VERGLASUNGSDICHTUNG ANBRINGEN INSTALLING THE GLAZING SEAL

Le joint caoutchouc est à poser sur les profilés de toiture, parois et porte.
Die Gummidichtung ist auf allen Dach-, Wand- und Türprofile anzubringen.
The rubber seal is to be attached on all the roof, wall and door profiles.

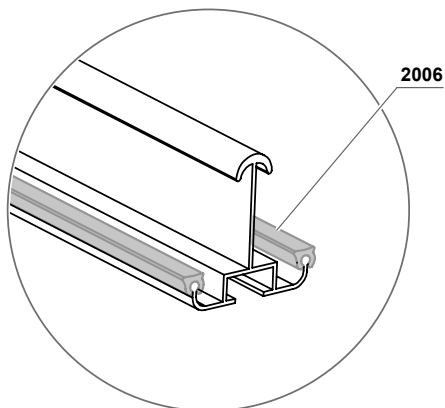

Module de base
Basismodul
Basic module

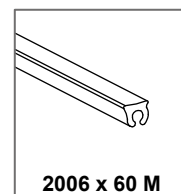

VITRAGE + POSE LUCARNE



Crochets de vitrage

Clips de vitrage

Module de base

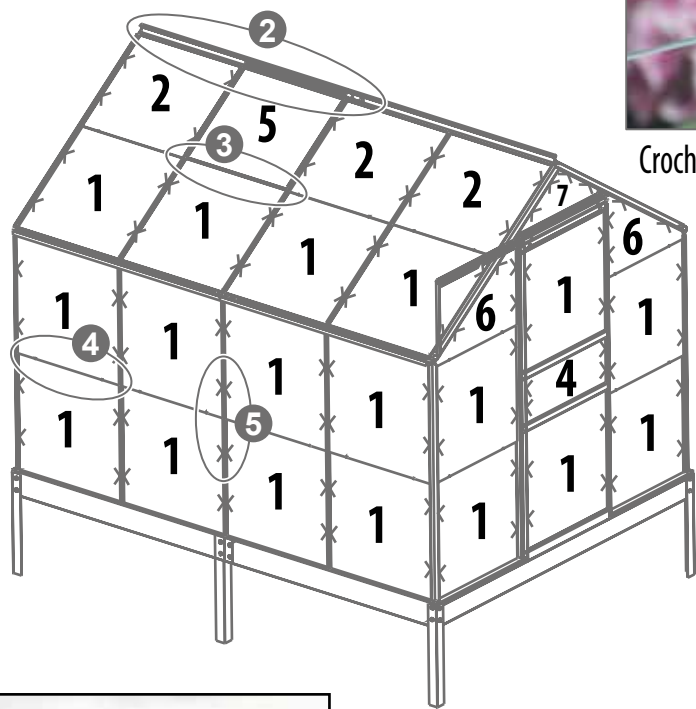

Nous vous conseillons d'installer les verres niveau par niveau (du bas vers le haut).

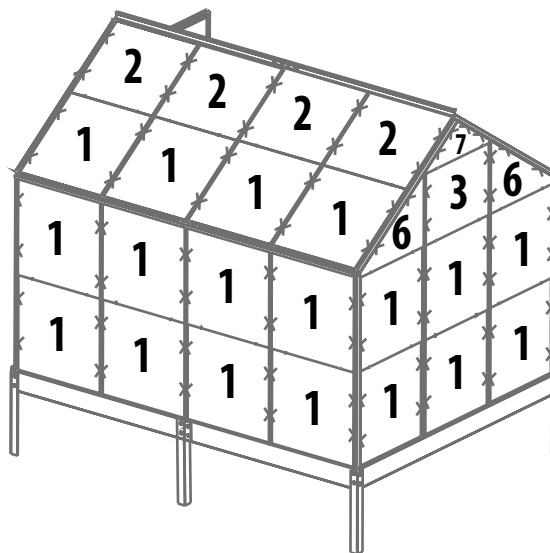

Lucarne
Vue extérieure

Il peut être nécessaire de dévisser temporairement certains profilés pour la mise en place des verres. Resserer correctement les vis après la pose des verres.

610 x 610	
1 x 36	
610 x 544	
2 x 7	
610 x 467	
3 x 1	
610 x 229	
4 x 1	
610 x 464/38	
6 x 4	
610 x 20/234/20	
7 x 2	
39001 x 1	
W006 x 52	
W007 x 204	
1001 x 2	
1002 x 2	
1005 x 4	
2005 x 2	

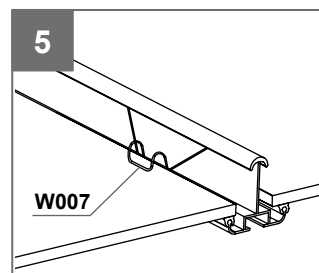
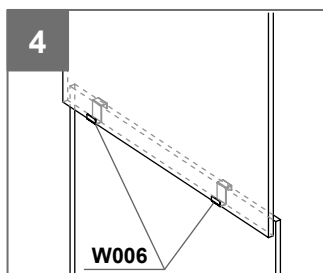
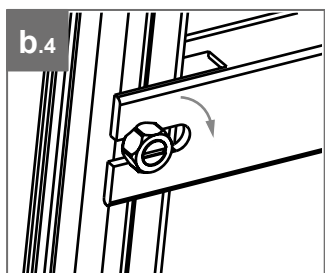
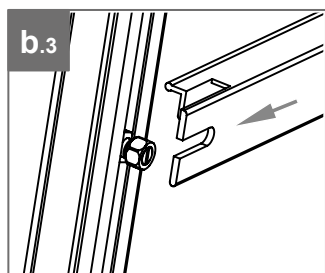
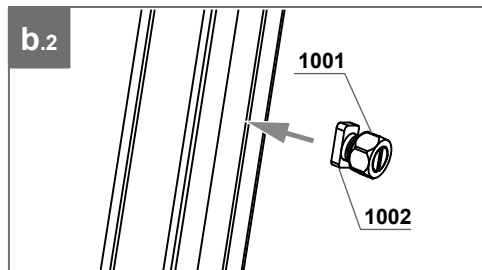
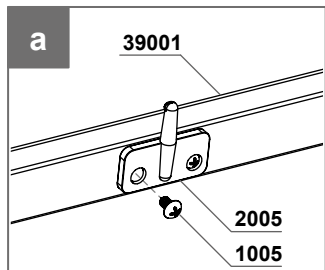
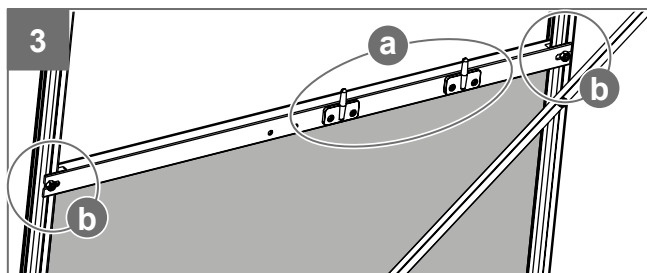
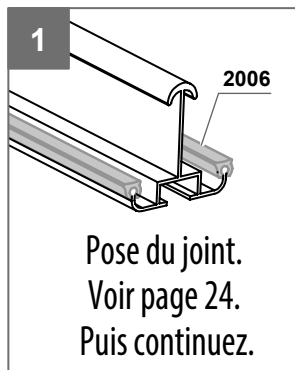



VERGLASUNG + FENSTER EINBAUEN



Verglasungshaken



Gewächshausklammern



Basismodul

610 x 610



1 x 36

610 x 544



2 x 7

610 x 467

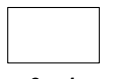

3 x 1

610 x 229

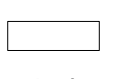

4 x 1

610 x 464/38

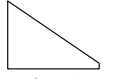

6 x 4

610 x 20/234/20

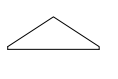

7 x 2



39001 x 1

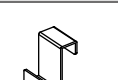

W006 x 52



W007 x 204



1001 x 2

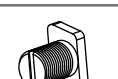

1002 x 2



1005 x 4



2005 x 2

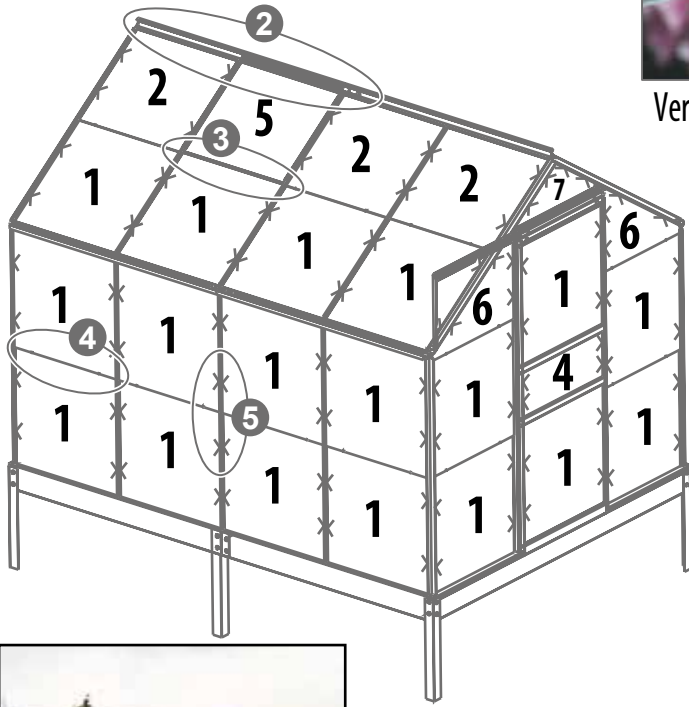

Wir empfehlen Ihnen, die Gläser Ebene für Ebene anzubringen (von unten nach oben).

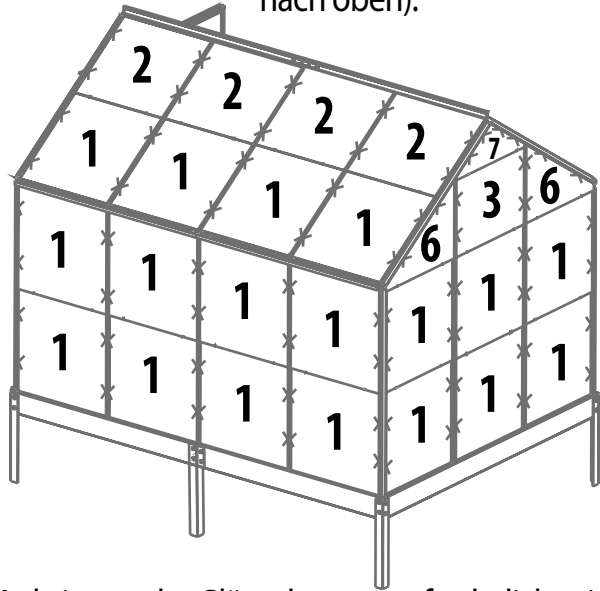

Fenster Außenansicht

Zum Anbringen der Gläser kann es erforderlich sein, bestimmte Profile vorübergehend abzuschrauben. Schrauben Sie diese nach der Anbringung der Gläser wieder fest.

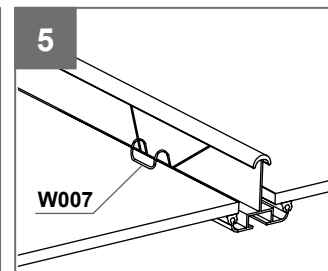
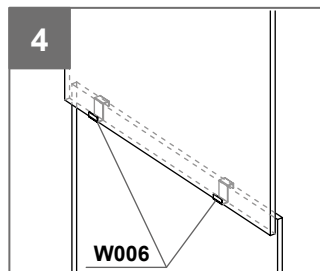
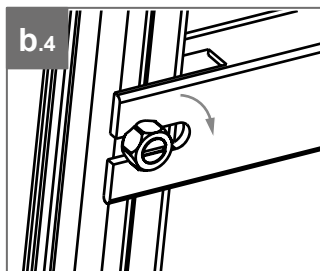
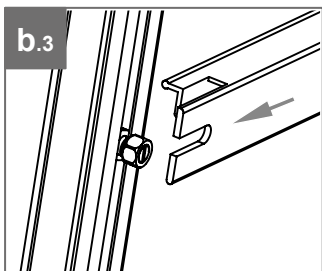
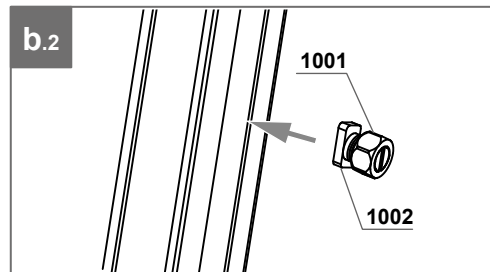
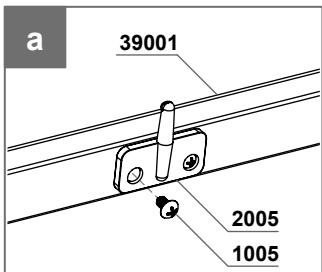
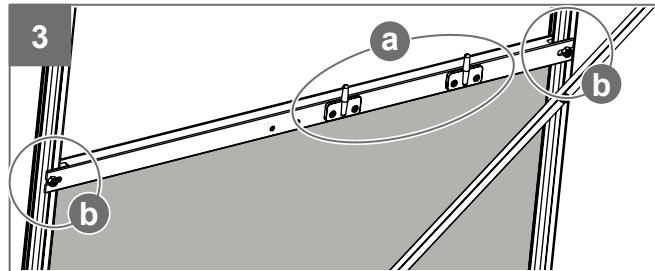
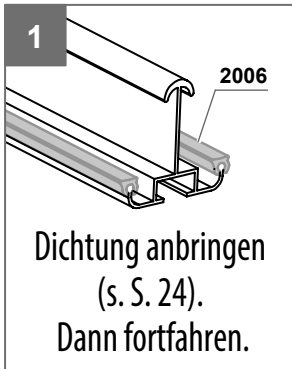

GLAZING + INSTALLING WINDOW



Glazing hooks

Glazing clips

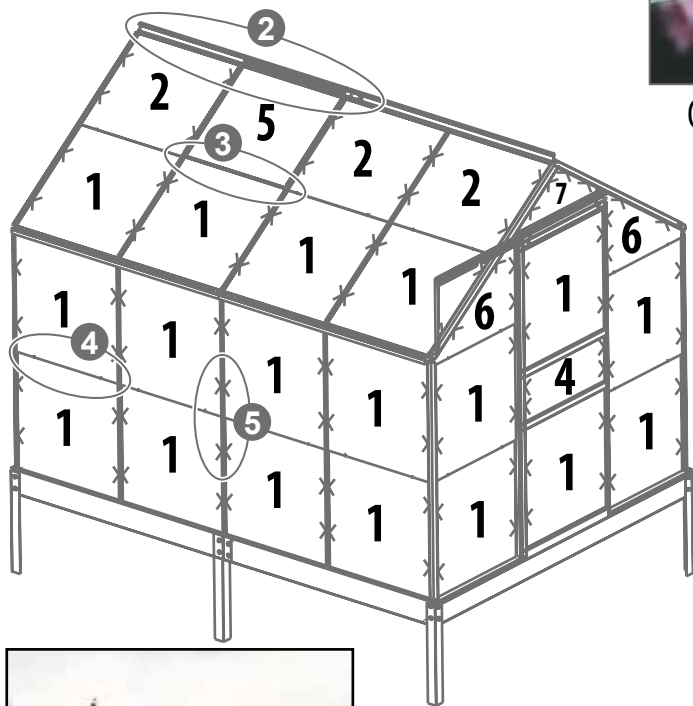

We advise you to install the glazing level by level (from bottom to top).

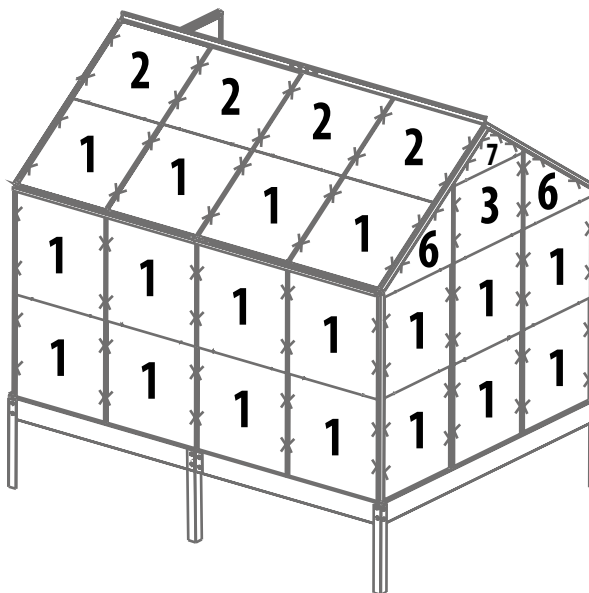

Window
Exterior view

Some profiles may need to be temporarily unscrewed to install the glazing. Refix the screws correctly after installing the glazing.

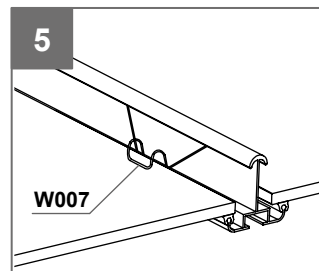
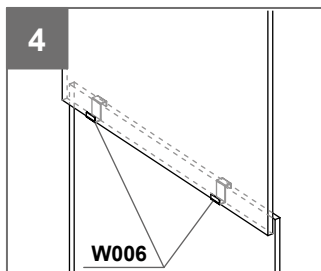
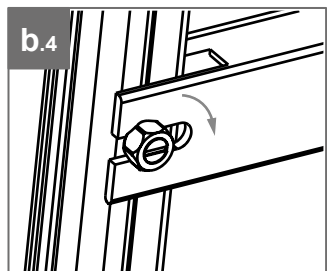
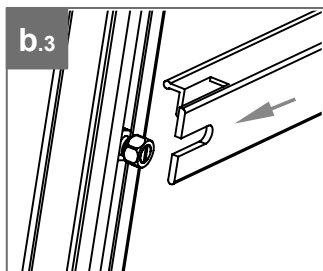
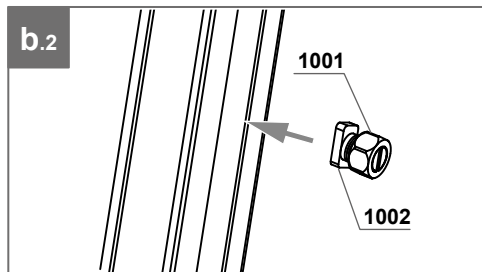
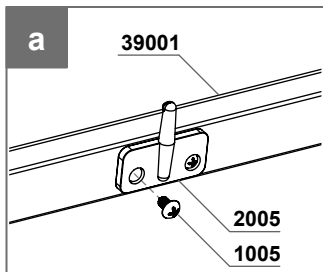
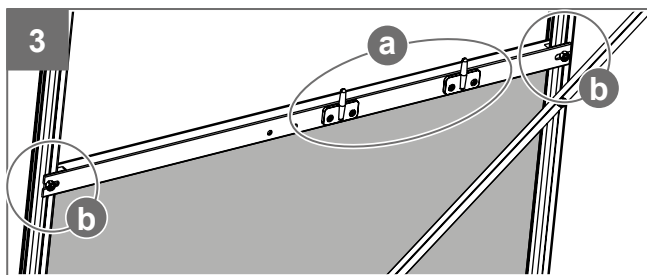
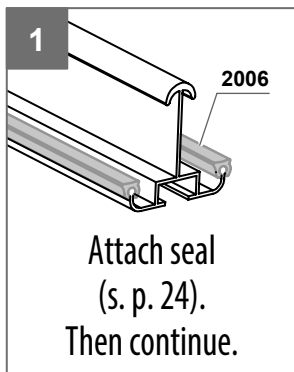

Basic module

610 x 610	
1 x 36	
610 x 544	
2 x 7	
610 x 467	
3 x 1	
610 x 229	
4 x 1	
610 x 464/38	
6 x 4	
610 x 20/234/20	
7 x 2	
39001 x 1	
W006 x 52	
W007 x 204	
1001 x 2	
1002 x 2	
1005 x 4	
2005 x 2	

MONTAGE DES PIÈCES PLASTIQUES

MONTAGE DER KUNSTSTOFFTEILE

INSTALLING THE PLASTIC PARTS



Détail embout de faîtière (pièce 2010)
 Abdeckung der Firstspitze (Einzelteil 2010)
 Roof ridge end cover (part 2010)

Module de base Basismodul Basic module

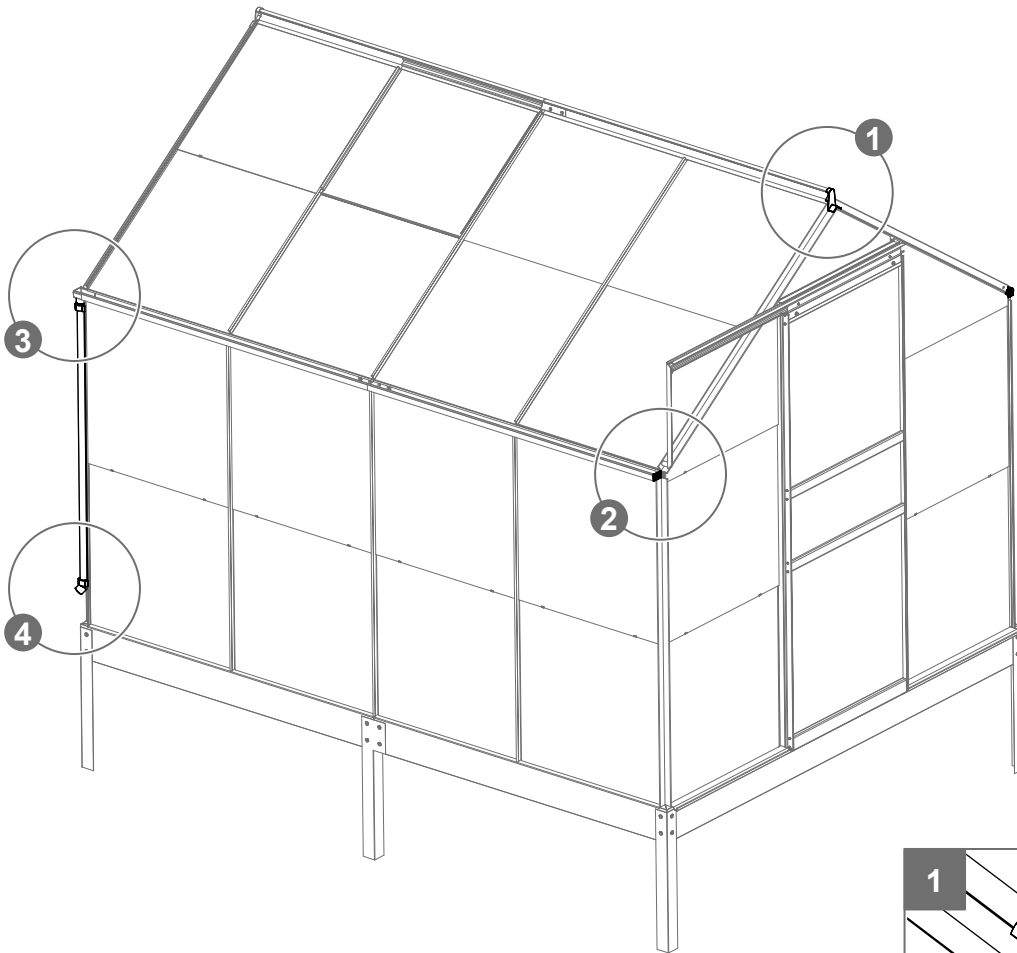

1005 x 4



2010 x 2

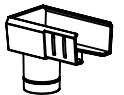

2022 x 2



2023 x 2



2028 x 2



2032 x 2

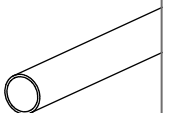

2041 x 2

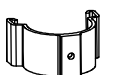

58001 x 4

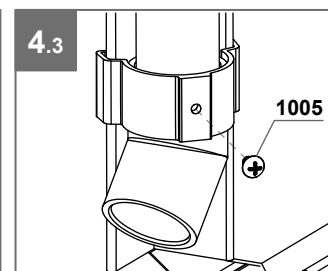
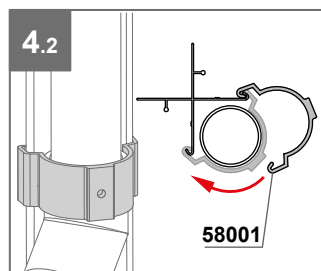
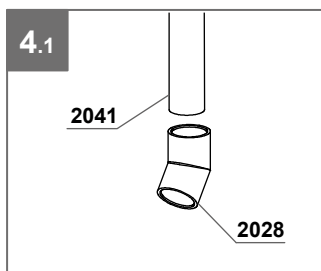
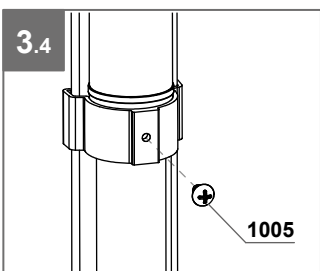
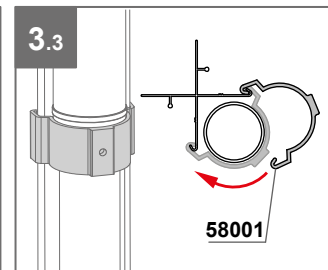
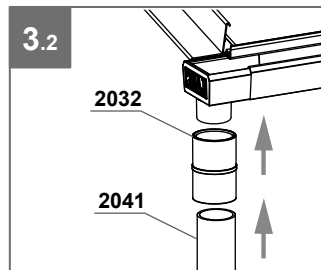
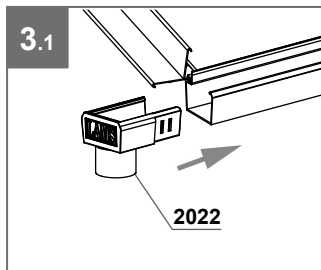
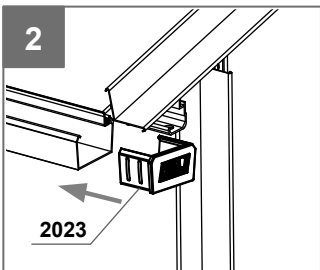
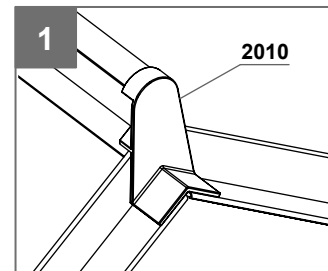

SERRE - GEWÄCHSHAUS - GREENHOUSE

ALLIUM 7,30 M²







Module de base 4,90 m² + module d'extension 2,40 m²



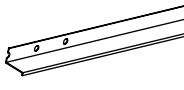
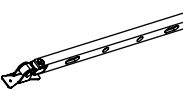



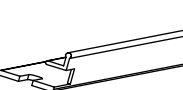

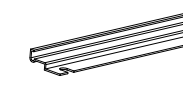
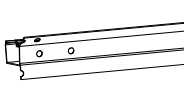
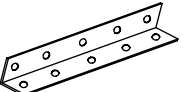
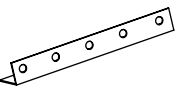

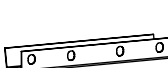
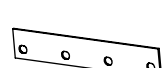
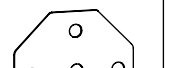
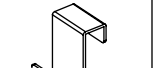

Basismodul 4,90 m² + Erweiterungsmodul 2,40 m²

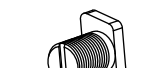
Basic modul 4,90 m² + extension module 2,40 m²

NOMENCLATURE EXTENSION - STÜCKLISTE ERWEITERUNG BILL OF MATERIALS EXTENSION



Colis - Paket - Parcel

PROFILÉS ALUMINIUM - ALUMINIUMPROFILE - ALUMINIUM PROFILES						
01006 x 2  L:1244 mm	15001 x 1  L:270 mm	25001 x 4  L:1133 mm	25002 x 4  L:1214 mm	38002 x 1  L:1244 mm	39001 x 1  L:634 mm	40001 x 1  L:602 mm
41001 x 2  L:518 mm	42001 x 1  L:602 mm	43003 x 2  L:1244 mm	45001 x 1  L:400 mm	46001 x 2  L:250 mm		

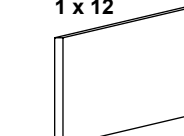
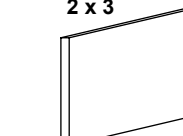
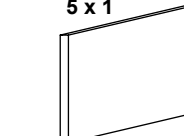
PETITS COMPOSANTS - KLEINTEILE - SMALL COMPONENTS							
W002 x 2 	W004 x 2 	W005 x 2 	W006 x 14 	W007 x 60 	W011 x 2 	W012 x 4 	1001 x 80  M6
1002 x 58  M6 x 12 mm	1003 x 6  M6 x 8 mm	1005 x 6  M3.5 x 6 mm	1015 x 2  M6	1011 x 16  M6 x 14 mm	2004 x 1 	2005 x 2 	2006 x 19 m 

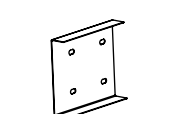
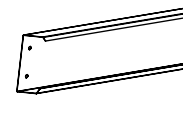
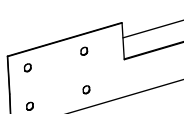
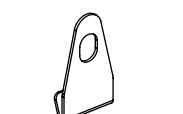
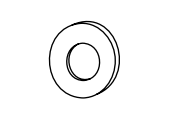
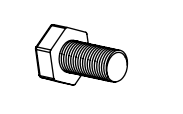
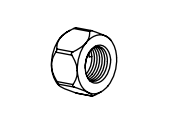
POLYCARBONATES - PC-STEGPLATTEN - POLYCARBONATE PANELS							
1 x 12  610 x 610 mm	2 x 3  610 x 544 mm	5 x 1  600 x 544 mm					

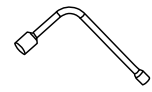
BASE ET VISSERIE - FUNDAMENTRAHMEN UND SCHRAUBEN - GREENHOUSE BASE AND SCREWS						
D003 x 2 	D006 x 2  1244 x 125 x 30 mm	D022 x 2 	W008 x 6 	1008 x 8  M6	1009 x 8  M6 x 12 mm	1010 x 8  M6

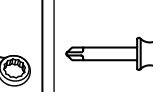
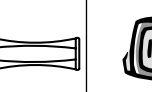
OUTILS INCLUS VORHANDENES WERKZEUG TOOLS INCLUDED		NON INCLUS NICHT VORHANDEN NOT INCLUDED	
 M6/10 mm	 M6/10 mm		 5 m

MONTAGE BASE - MONTAGE FUNDAMENTRAHMEN - BASE ASSEMBLING

Module de base
Basismodul
Basic module

Il est impératif que la base soit montée de niveau.



Es ist zwingend erforderlich, dass der Fundamentrahmen auf einem ebenen Untergrund montiert wird.

It is imperative that the greenhouse base is leveled.

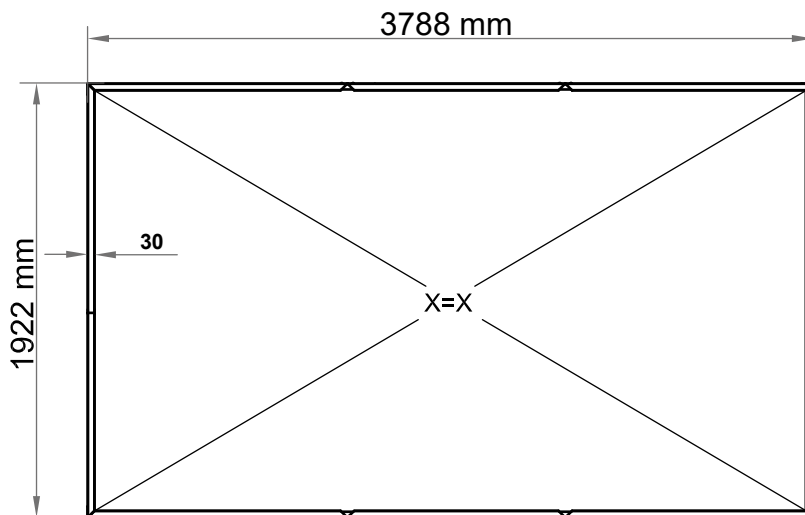

Plots béton / Punktfundament / Point foundation : D004 + D005 + D022.

Dalle ou pourtour béton / Streifenfundament / Concrete slab or frame : D004.

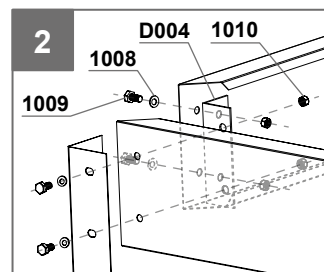
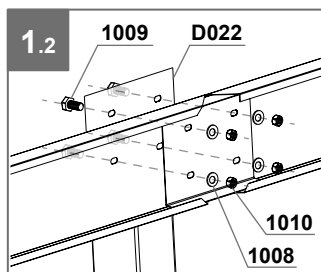
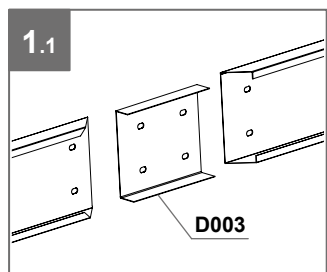
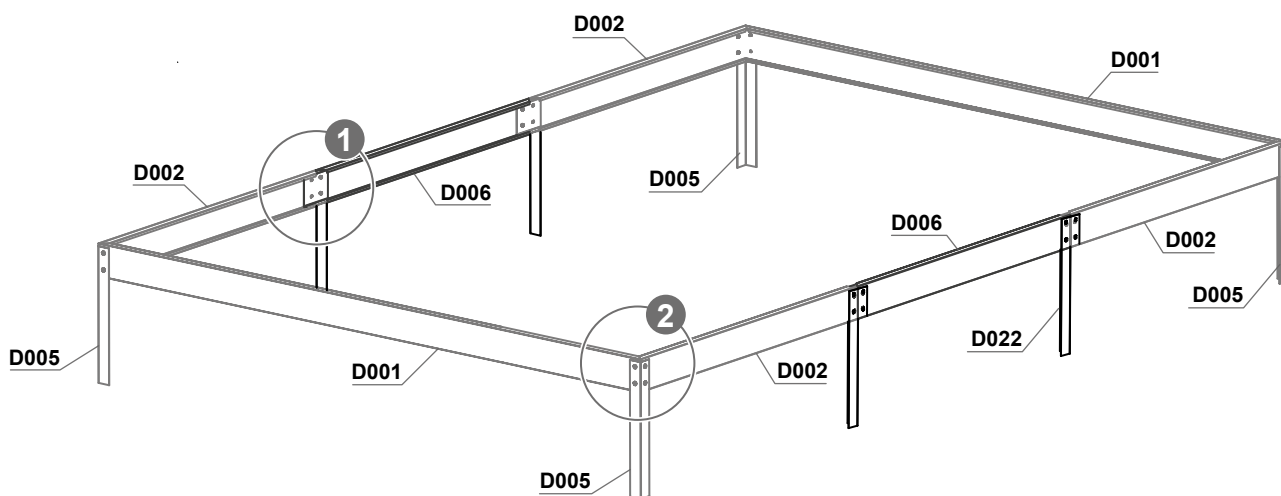

Module d'extension
Erweiterungsmodul
Extension module

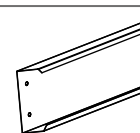

D001 x 2

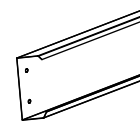

D002 x 4

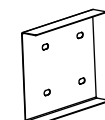

D003 x 2

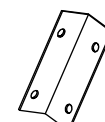

D004 x 4

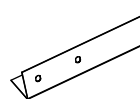

D005 x 4

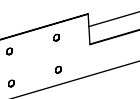

D022 x 2

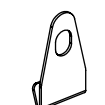

W008 x 16



1008 x 24



1009 x 24

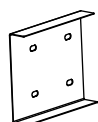

D003 x 2

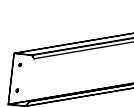

D006 x 2

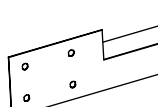

D022 x 2



W008 x 6



1008 x 8



1009 x 8



1010 x 8

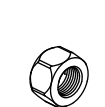

1010 x 24



FIXATION DE LA BASE AU SOL

FIXATION EN PLEINE TERRE

- Positionner la base à l'endroit voulu, de niveau sur un sol damé.
- Repérer l'emplacement des pattes de scellement suivant le schéma ci-dessous.
- Marquer un carré de 300 x 300 mm autour des pattes de scellement et creuser sur une profondeur de 450 mm.
- Placer la base, la mettre de niveau et remplir les trous de béton.

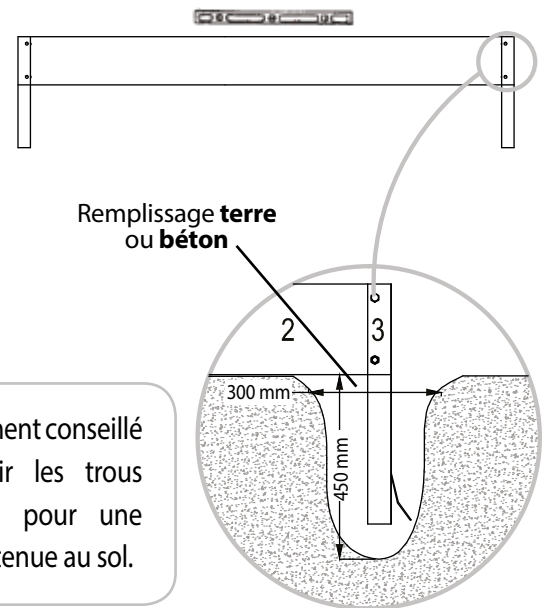
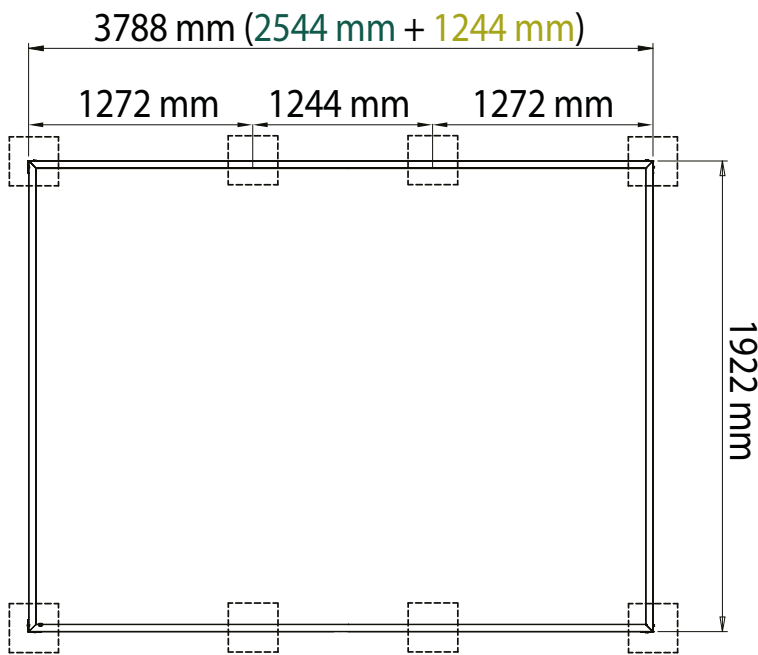

Il est vivement conseillé de remplir les trous de béton pour une meilleure tenue au sol.

OU

FIXATION SUR DALLE BÉTON

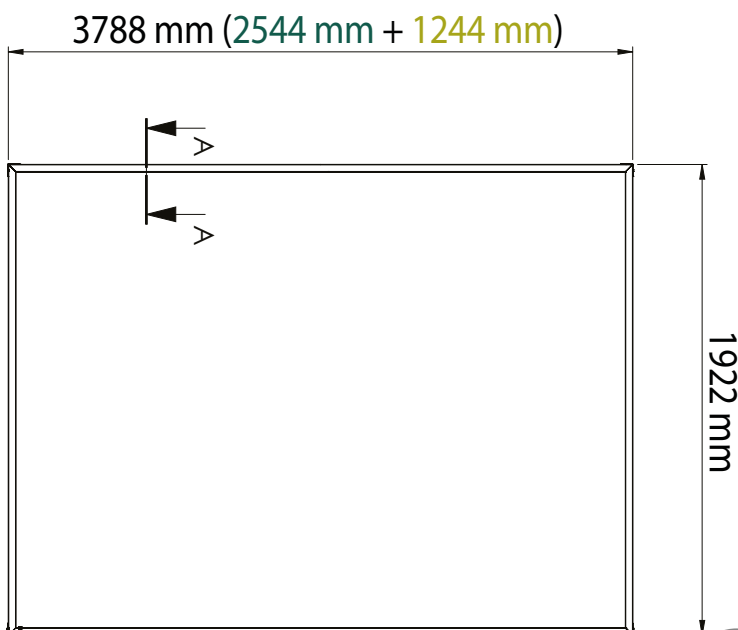

Détail A-A

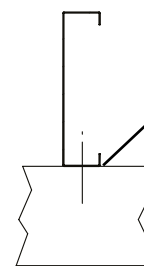

Fixation par chevilles à l'intérieur de la base



Visseries et chevilles de fixation non fournies

Il est laissé à votre libre choix et décision, l'utilisation des fixations adéquats selon les supports que vous décidez d'utiliser (pourtour bois, parpaings, plaques ciment, ...).



BEFESTIGUNG DES FUNDAMENTRAHMENS AM BODEN

BEFESTIGUNG AUF ERDBODEN (Punktfundament)

- Stellen Sie den Fundamentrahmen an der gewünschten Stelle, auf einem ebenen Boden.
- Finden Sie die Stelle der Ankerbeine gemäß dem untenstehenden Schema.
- Markieren Sie ein 300 x 300 mm Quadrat um die Ankerbeine herum und graben Sie 450 mm tief.
- Den Fundamentrahmen platzieren, nivellieren und die Löcher mit Beton füllen.

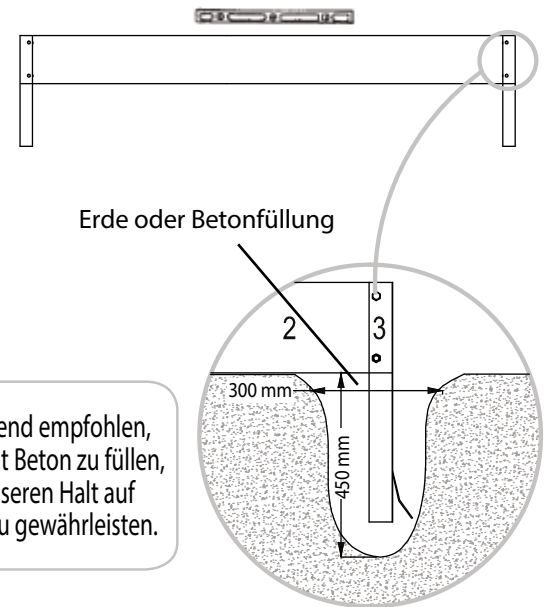
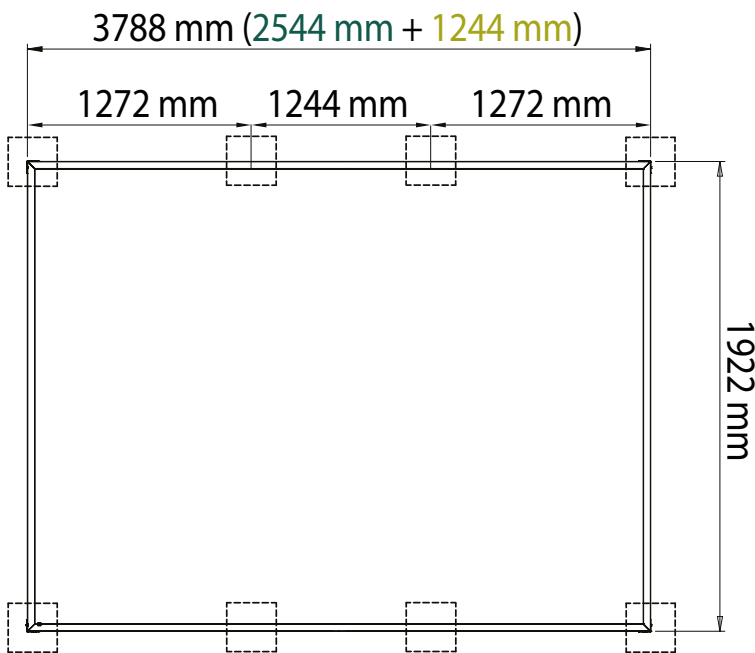

Es wird dringend empfohlen, die Löcher mit Beton zu füllen, um einen besseren Halt auf dem Boden zu gewährleisten.

ODER

BEFESTIGUNG AUF BETONDECKE (Streifenfundament)

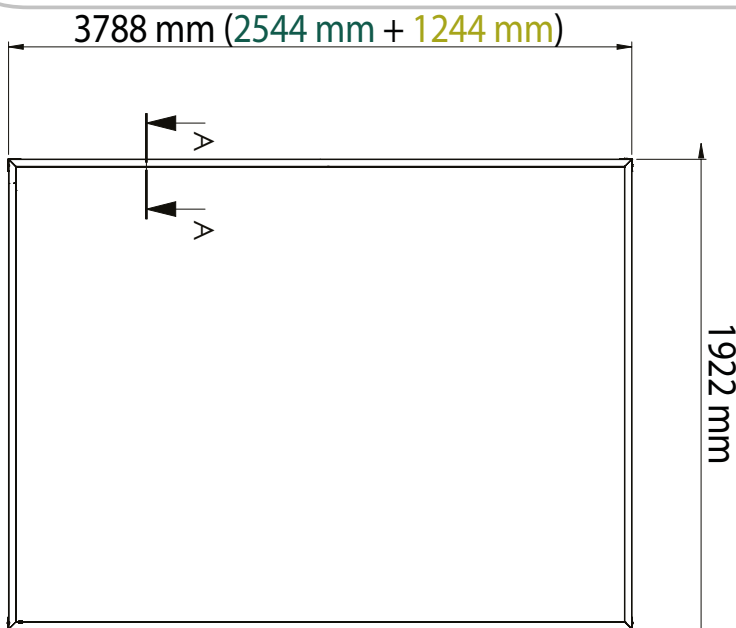

Detail A-A



Es bleibt Ihrer freien Wahl und Entscheidung überlassen, die geeigneten Befestigungsmittel entsprechend der von Ihnen gewählten Träger (Holzumrandung, Bausteine, Zementplatten,...) zu verwenden.



FIXING THE GREENHOUSE BASE TO THE GROUND

FIXING ON SOIL (POINT FOUNDATION)

- Position the greenhouse base in the desired location at a level position.
- Locate the base legs as shown bellow.
- Mark a 300 x 300 mm square around the base legs and dig 450 mm deep.
- Place the greenhouse base, level it and fill the holes with concrete.

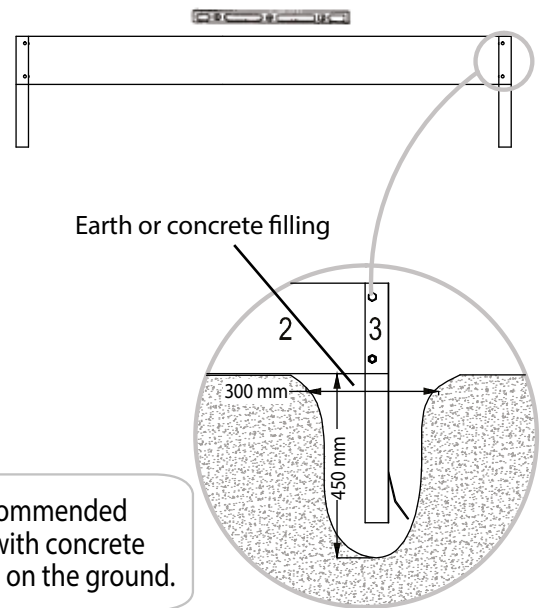
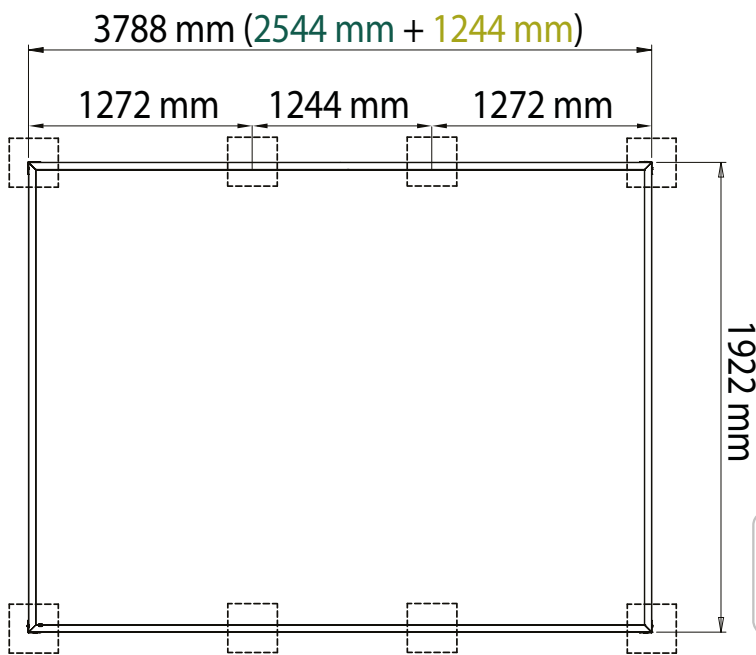

OR

FIXING ON CONCRETE SLAB

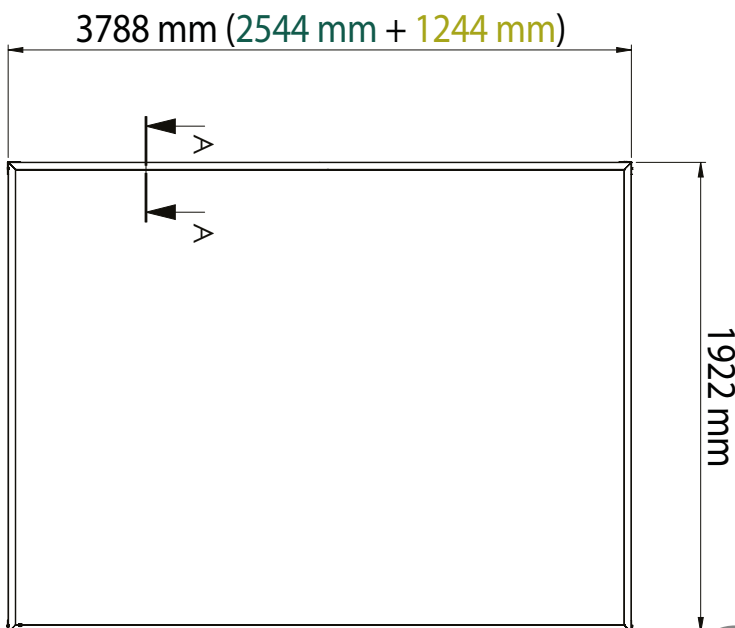

Detail A-A

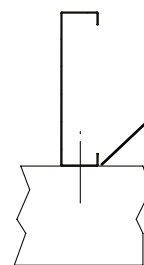

Rawplug fastening inside the greenhouse base



Screws and rawplugs not provided

It remains to your free choice and decision to use the suitable fastening means according to the supports you chose (wood border, building stones, cement plates etc.)

VIS 1002 & 1003 - SCHRAUBEN 1002 & 1003 - SCREWS 1002 & 1003

Mise en place des vis 1002 et 1003 dans les rainures en forme de T des profilés aluminium :
Entrez la tête de vis dans la rainure du profilé et tournez à 90° afin qu'elle ne puisse pas sortir du profilé. Assemblez la/les pièce(s) nécessaire(s) et serrez l'écrou.

Verwendung der Schrauben 1002 und 1003 in den t-förmigen Nuten der Aluminiumprofile :
Schraubenkopf in die Profilmutter stecken und diesen um 90° drehen, damit er nicht aus dem Profil herauskommt. Bauen Sie das/die benötigte(n) Einzelteil(e) zusammen und ziehen Sie die Schraubenmuttern an.

Principle of use of screws 1002 and 1003 in the T-shaped grooves of the aluminium profiles :
Enter the screw head into the groove of the profile and turn the screw head at 90° so that it cannot exit the profile. Assemble the required part(s) and tighten the screw nut.

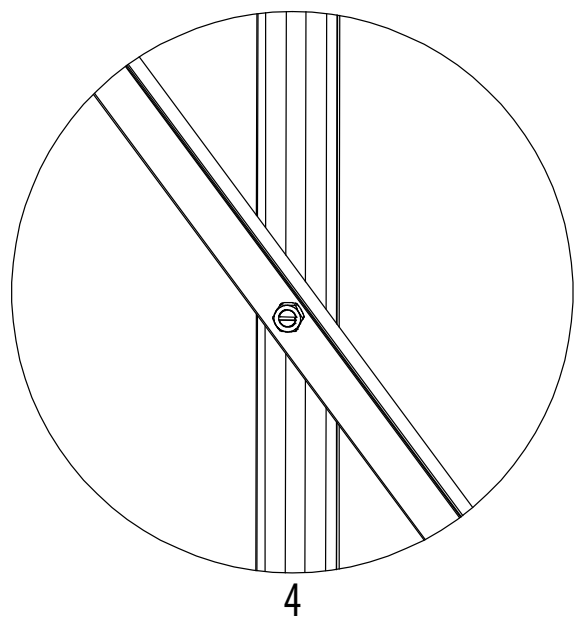
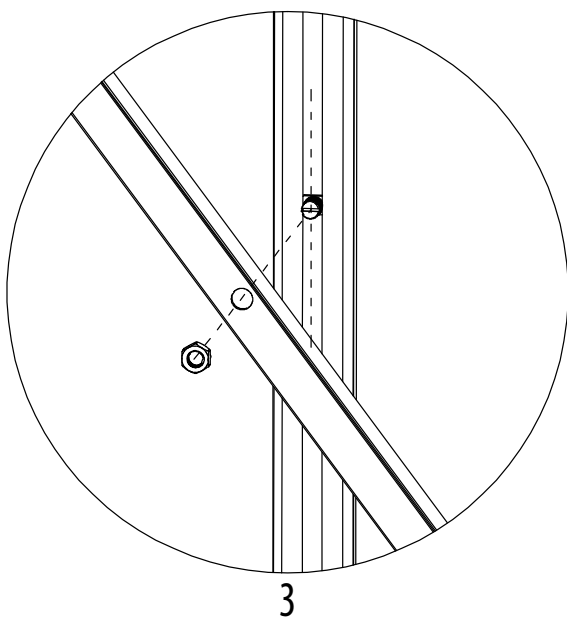
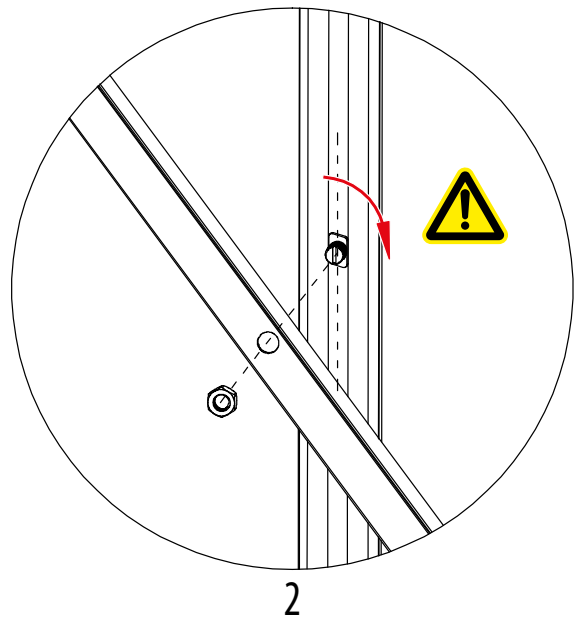
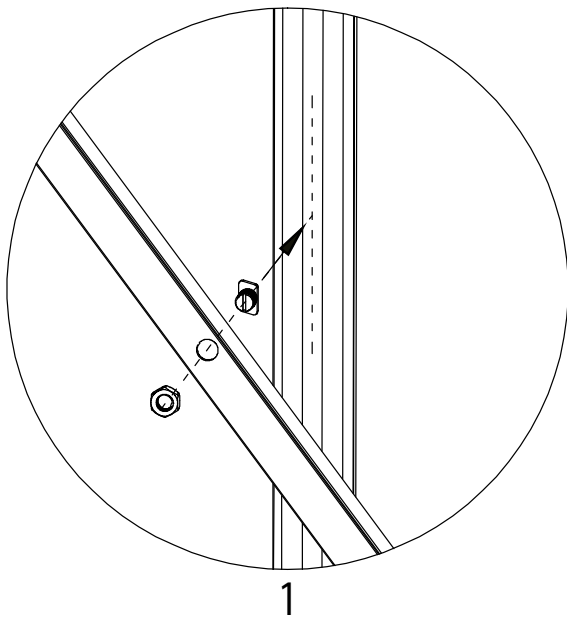

LONG-PAN (CÔTÉ) x2 - SEITENWAND x2 - SIDE WALL x2



Fixation des profilés de vitrage sur la traverse haute.
Befestigung der Verglasungsprofile am oberen Querträger.
Fastening the glazing profiles on the upper crossbeam.

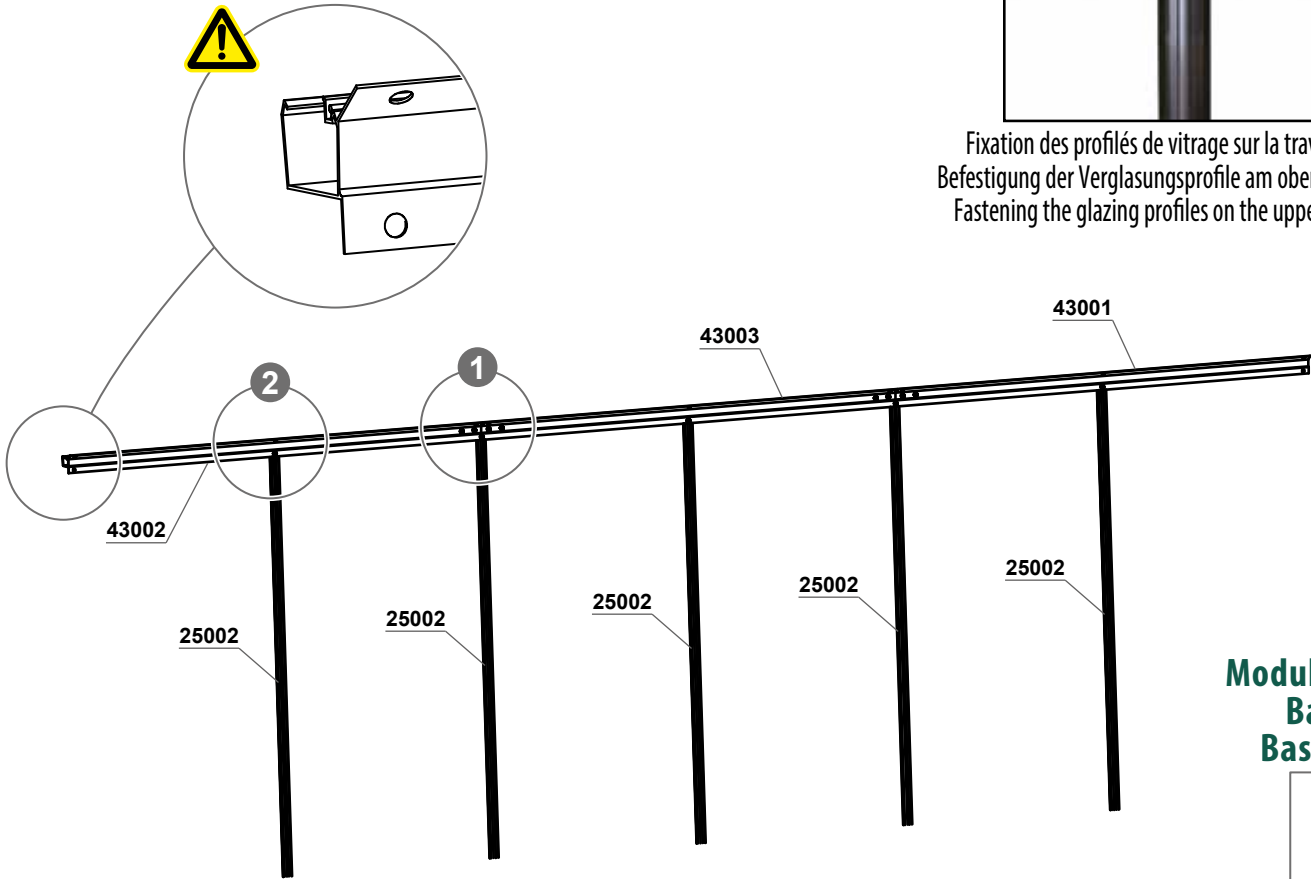

Module de base Basismodul Basic module

	25002 x 6
	43001 x 2
	43002 x 2
	W002 x 2
	1001 x 14
	1002 x 14

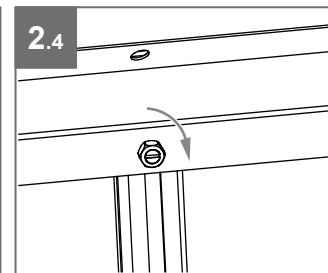
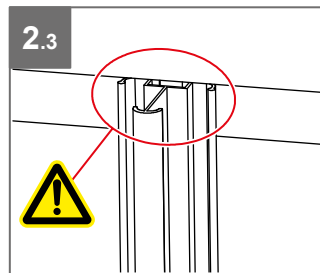
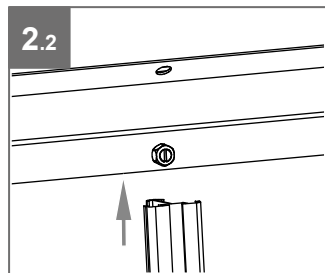
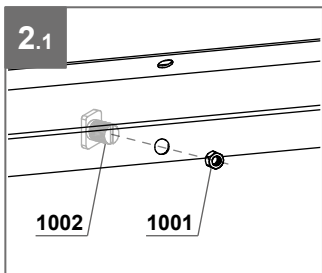
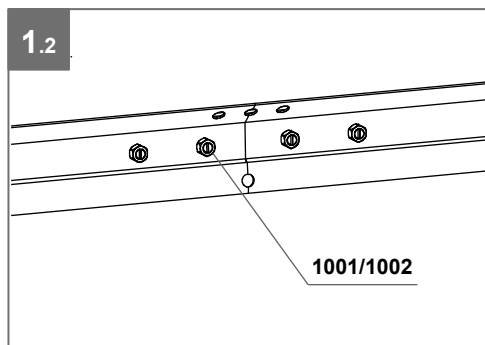
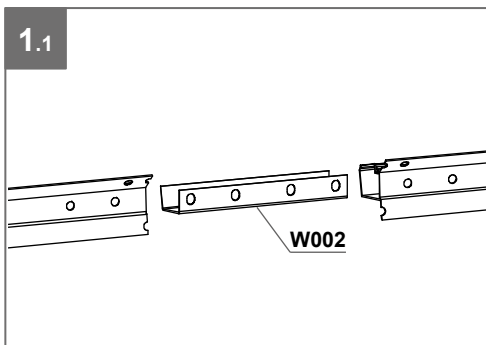

Module d'extension Erweiterungsmodul Extension module

	25002 x 4		43003 x 2		W002 x 2		1001 x 12		1002 x 12
--	-----------	--	-----------	--	----------	--	-----------	--	-----------

LONG-PAN (CÔTÉ) x2 - SEITENWAND x2 - SIDE WALL x2

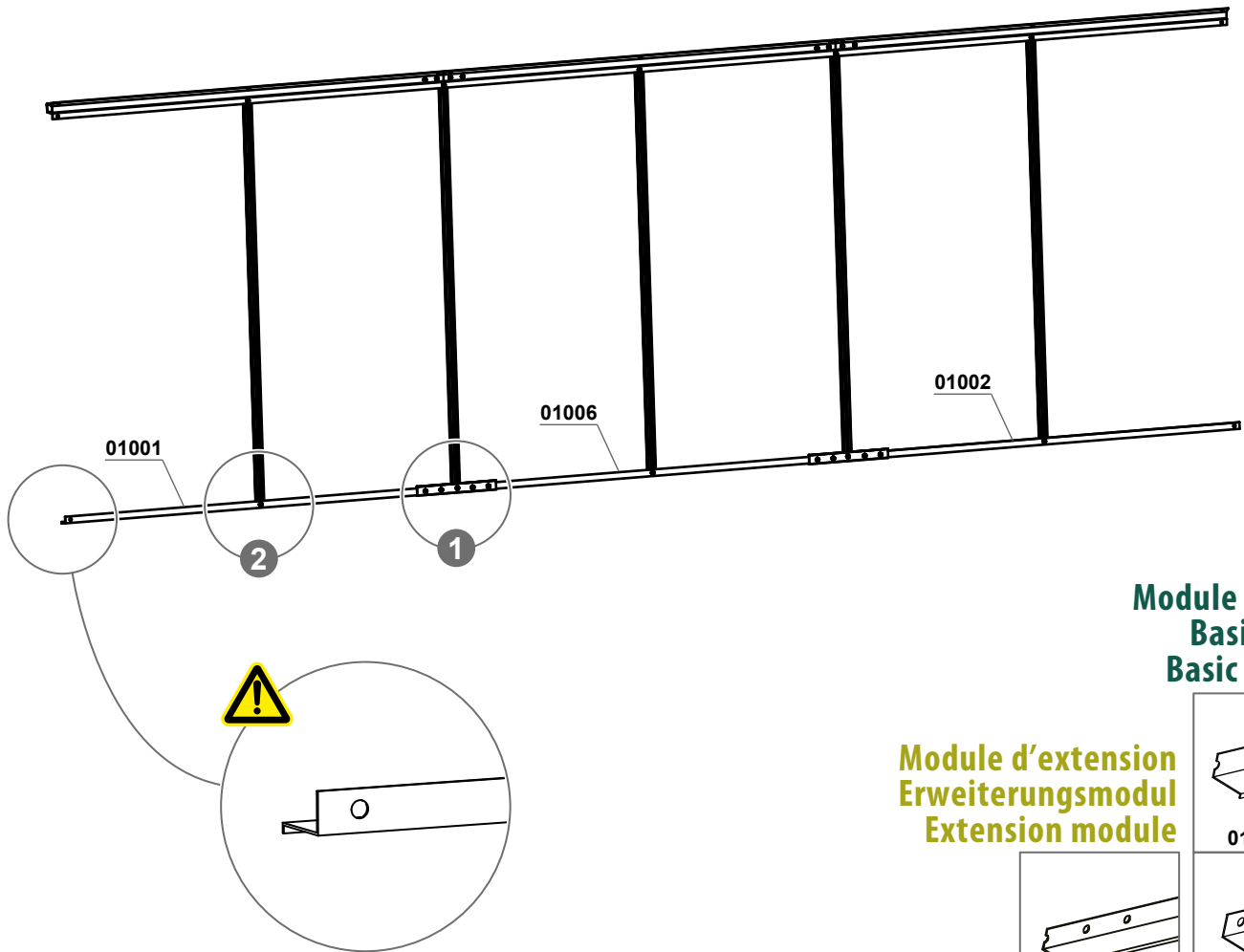

Module de base
Basismodul
Basic module

Module d'extension
Erweiterungsmodul
Extension module

	01001 x 2
	01006 x 2
	01002 x 2
	46001 x 2
	1001 x 12
	1001 x 14
	1002 x 4
	1002 x 6
	1011 x 8
	1011 x 8

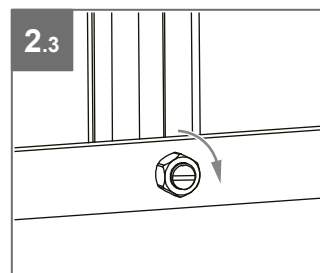
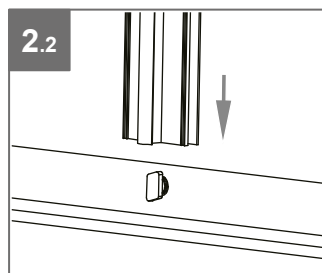
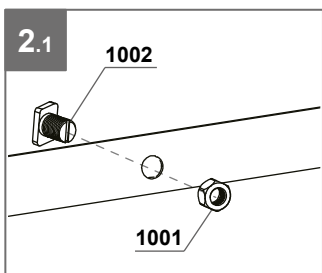
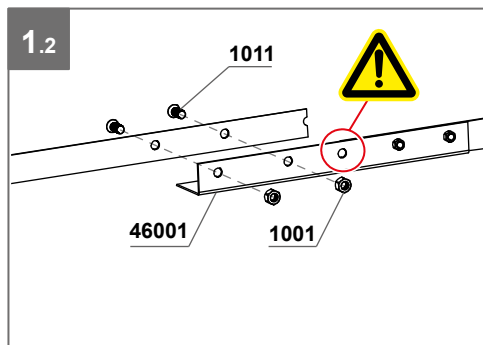
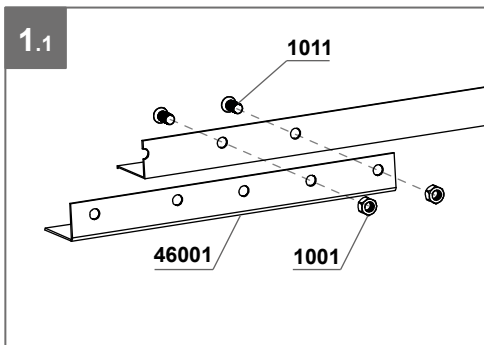

ÉTAPES SUIVANTES - NÄCHSTE SCHRITTE - NEXT STEPS

Montage de la face avant (avec porte) : page 15
Montage der Vorderwand (mit Tür) : Seite 15
Assembling the front wall (with door) : page 15

Montage de la face arrière (sans porte) : page 16
Montage der Rückwand (ohne Tür) : Seite 16
Assembling the rear wall (without door) : page 16

Montage de la porte : page 17
Montage der Tür : Seite 17
Assembling the door : page 17



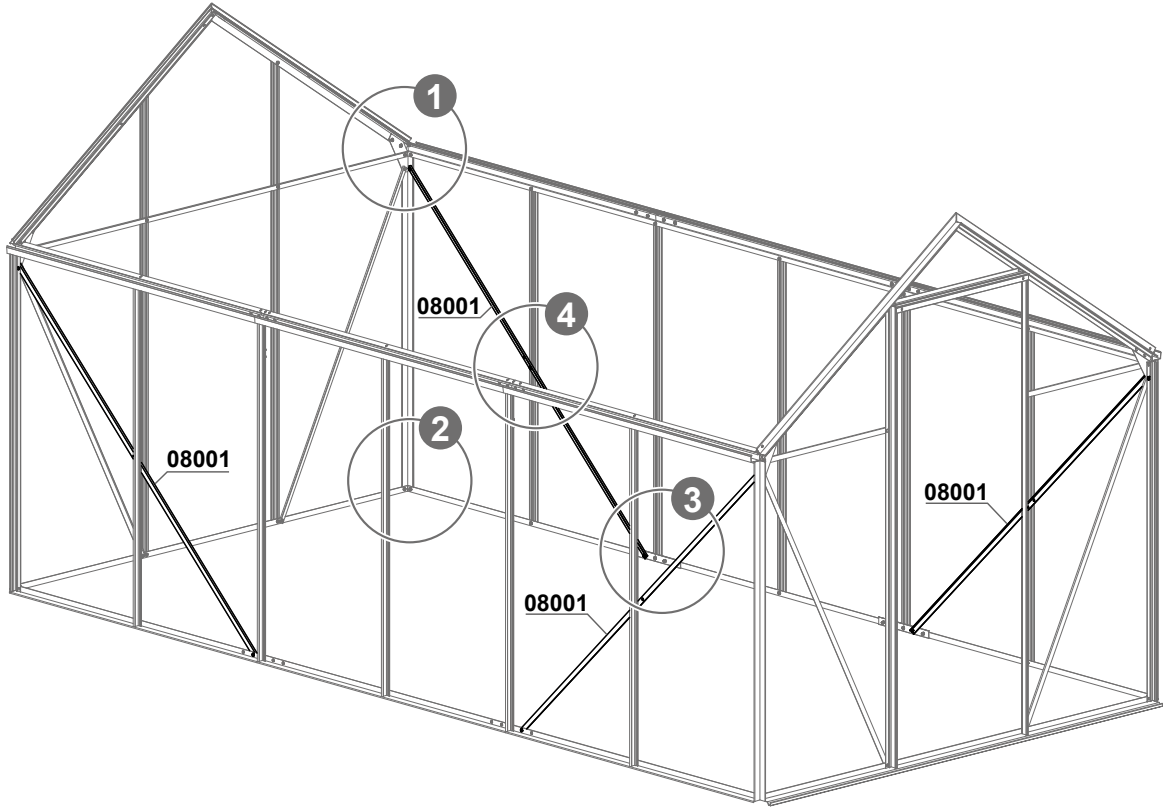

Montage de la lucarne : page 18
Montage des Fensters : Seite 18
Assembling the window : page 18

Puis revenir à la page 39
Dann zurück auf Seite 39
Then back to page 39

ASSEMBLAGE DES PAROIS - ZUSAMMENBAU DER WÄNDE ASSEMBLY OF THE WALLS

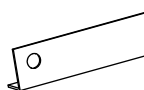

Module de base
Basismodul
Basic module

- 
08001 x 4
- 
1001 x 20
- 
1002 x 16
- 
1003 x 4

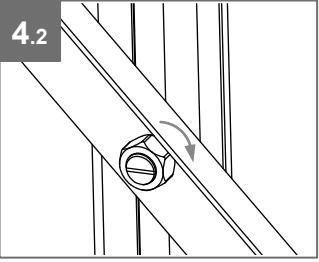
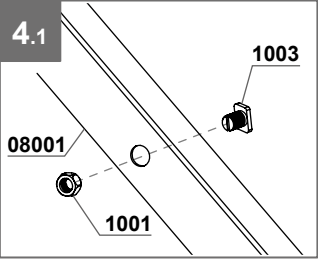
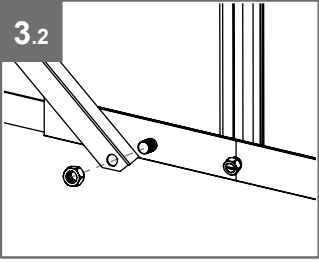
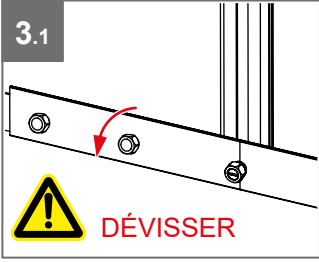
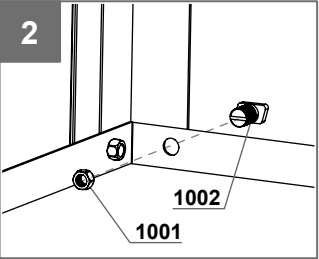
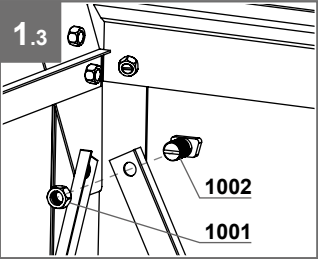
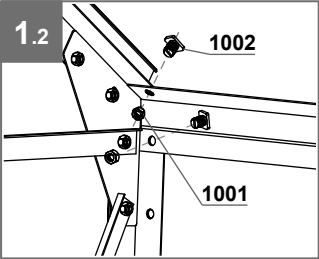
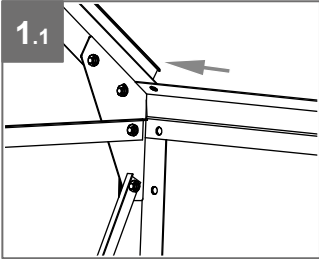

MONTAGE DES PROFILÉS DE TOITURE - MONTAGE DER DACHPROFILE ASSEMBLING THE ROOF PROFILES

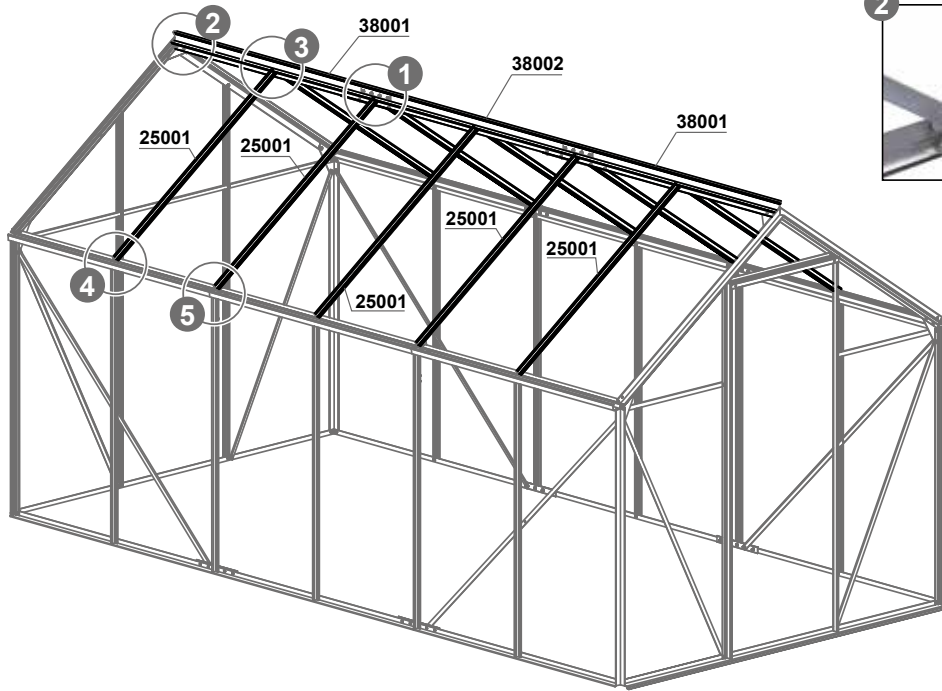

Module de base Basismodul Basic module

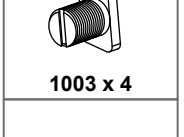
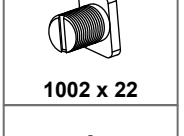
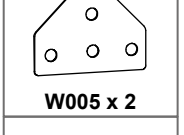
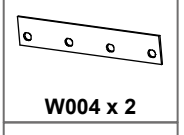
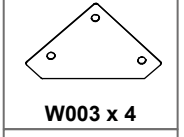
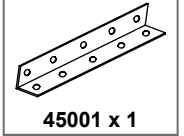
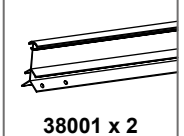
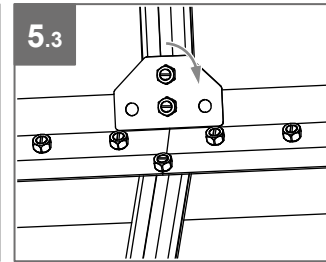
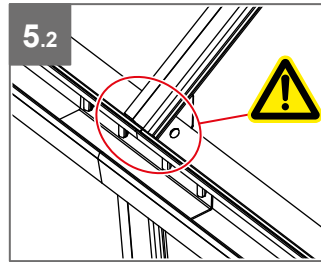
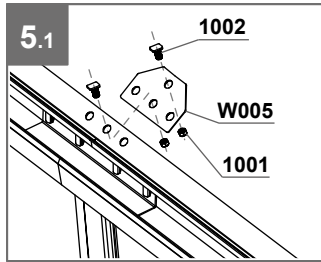
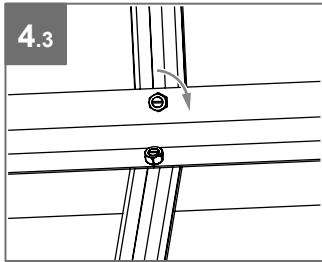
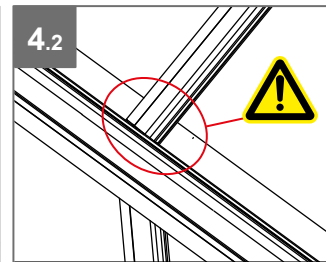
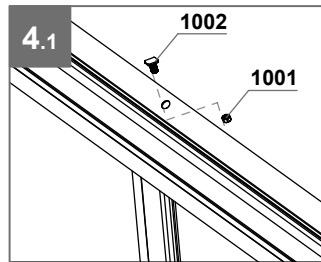
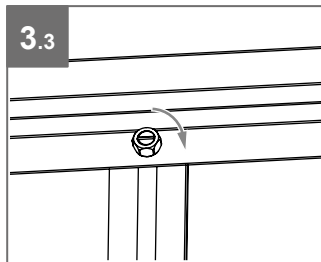
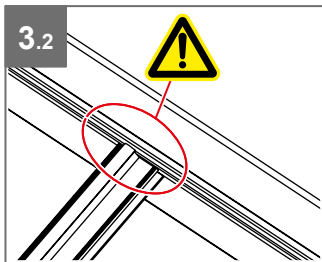
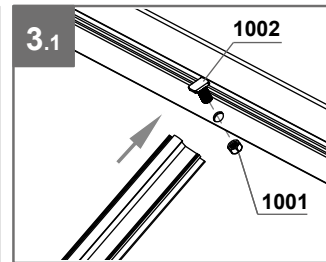
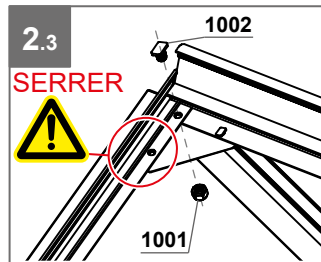
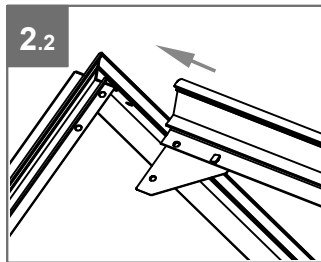
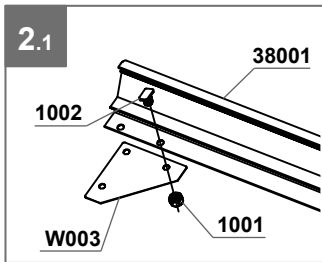
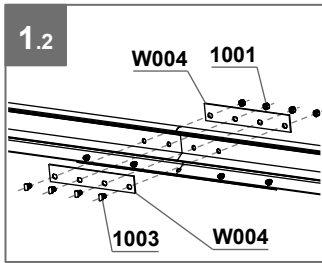
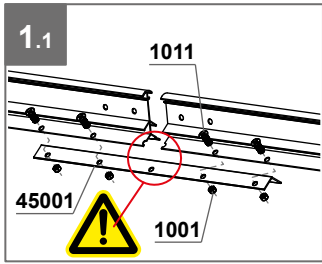

Module d'extension - Erweiterungsmodul - Extension module

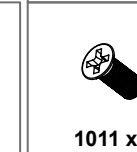
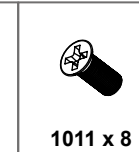
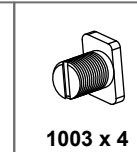
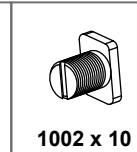
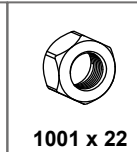
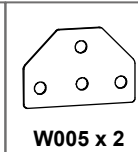
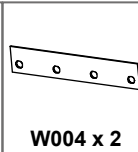
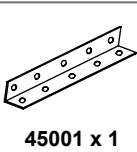
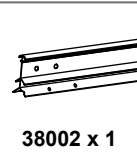
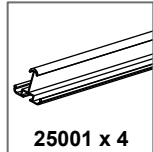

MONTAGE DES TENDEURS ET GOUSSETS SPANNVORRICHTUNG UND VERBINDER WIND BRACES AND GUSSETS

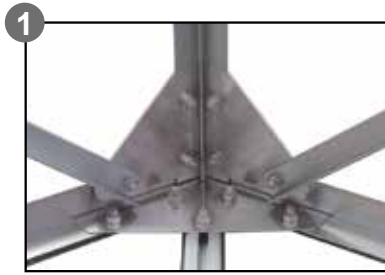
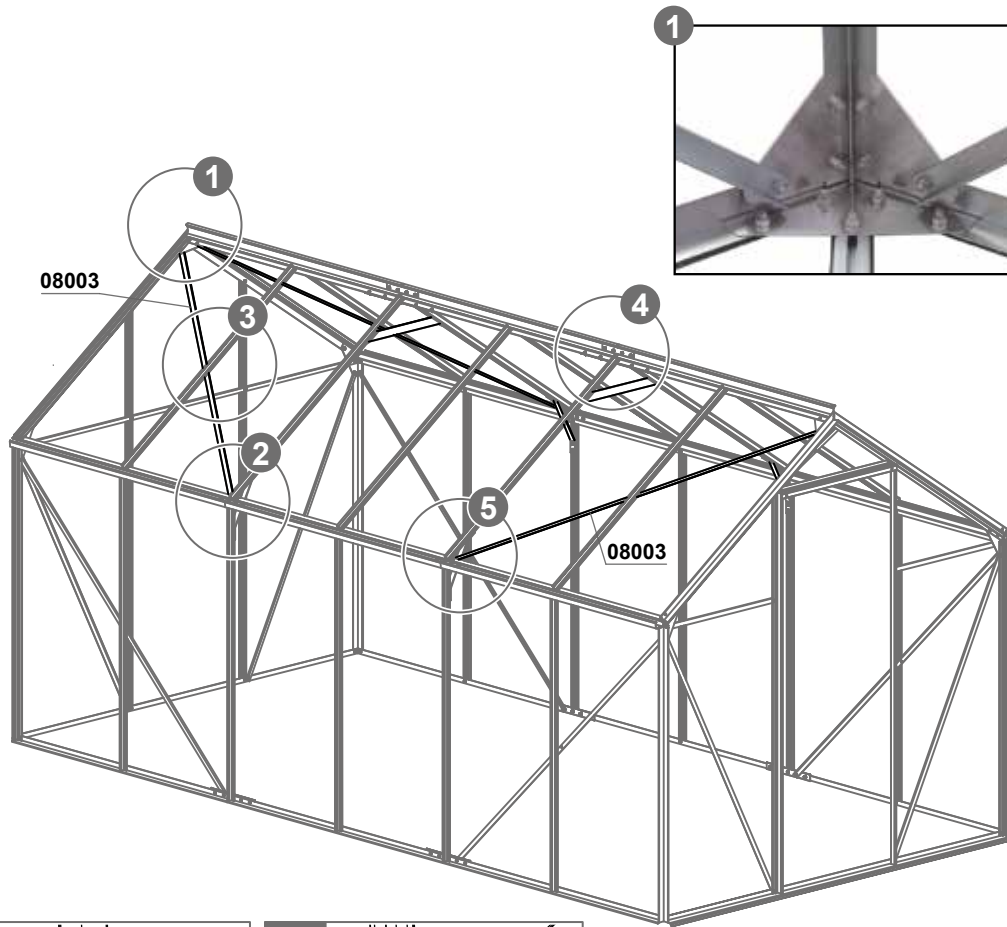

Module d'extension Erweiterungsmodul Extension module

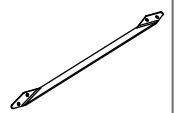

W011 x 2

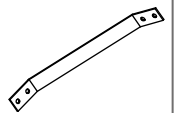

W012 x 4



1001 x 28



1002 x 28

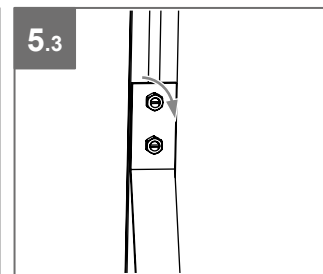
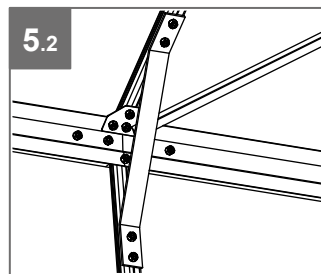
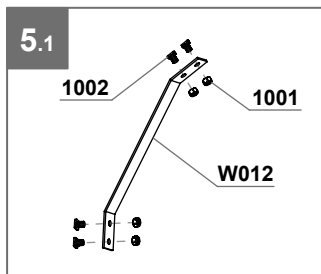
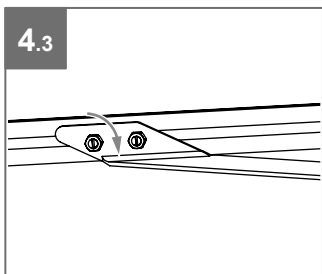
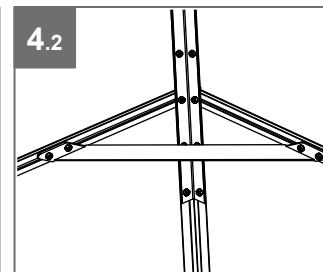
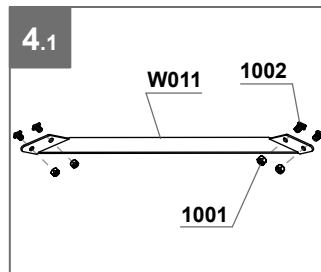
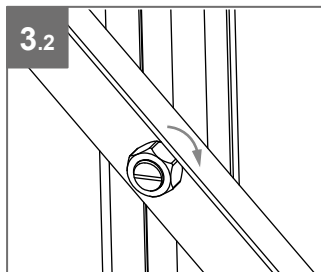
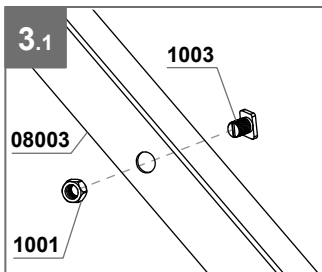
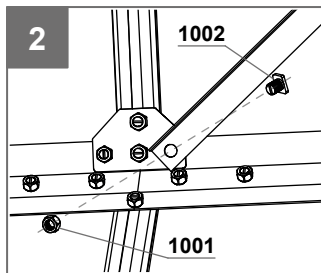
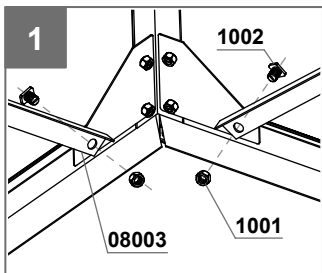

Module de base Basismodul Basic module

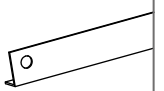

08003 x 4



1001 x 12



1002 x 8



1003 x 4

FIXATION DE LA SERRE SUR LA BASE BEFESTIGUNG DES GEWÄCHSHAUSES AM FUNDAMENTRAHMEN FASTENING THE GREENHOUSE BASE

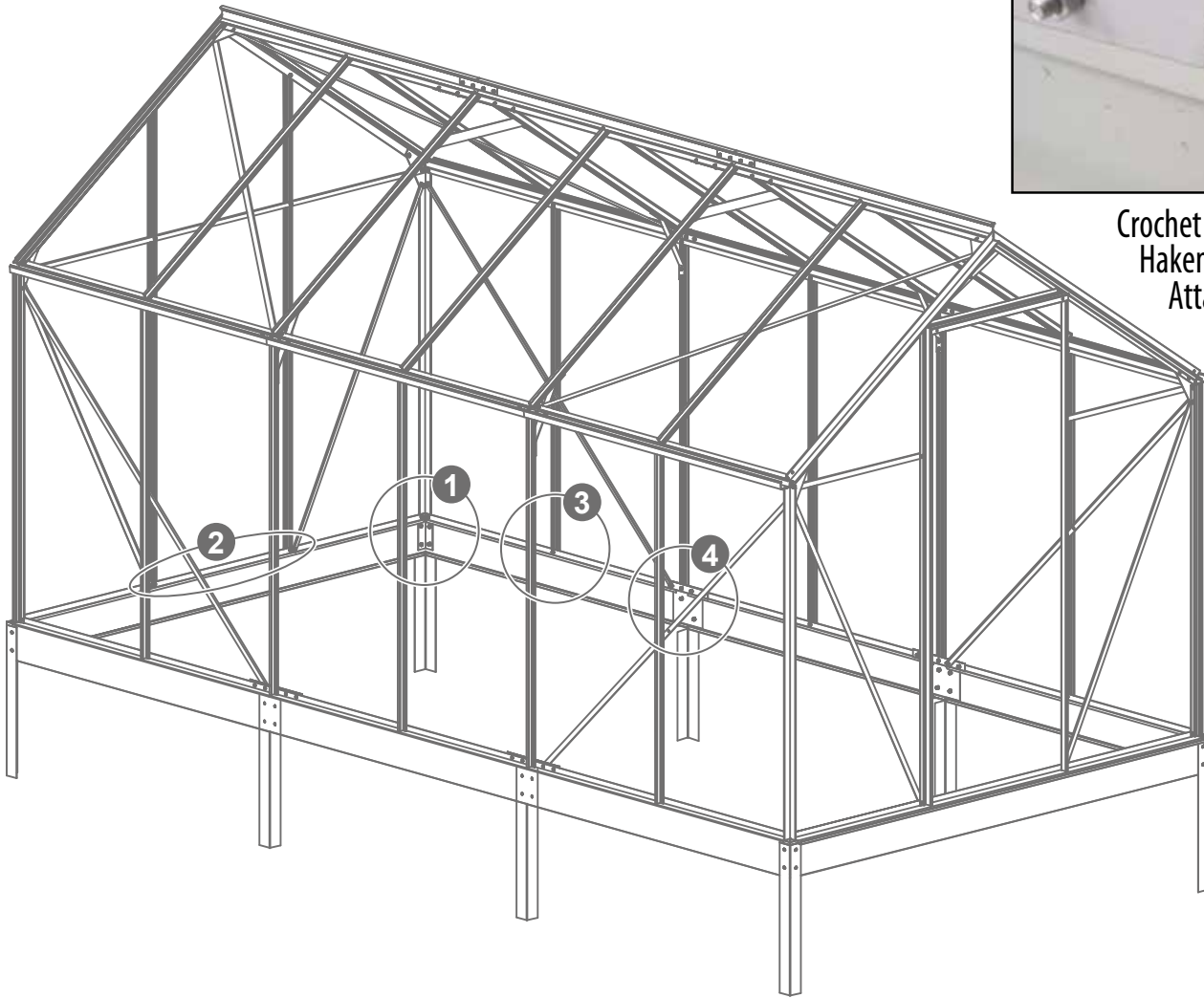

Crochet à positionner
Haken anbringen
Attach hook

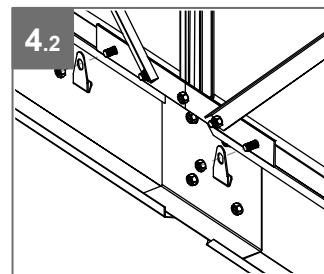
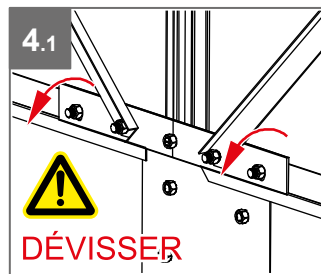
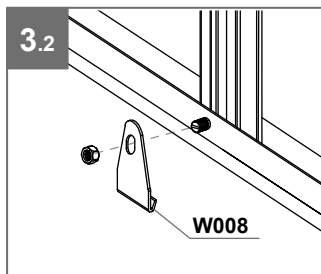
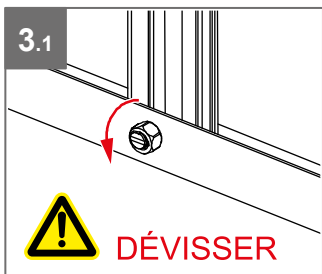
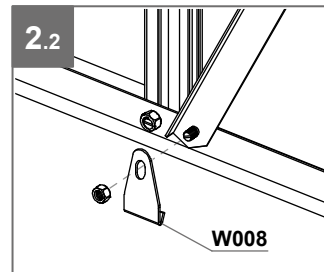
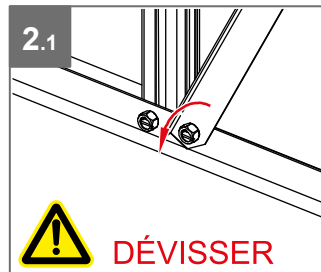
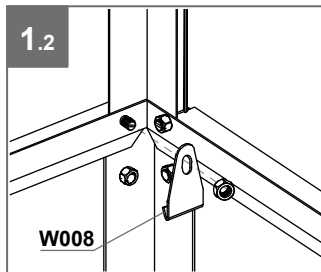
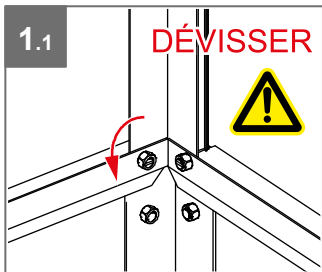

Module
d'extension
Erweiterungs-
modul
Extension
module

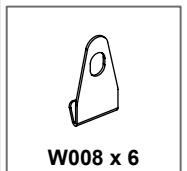

Module de base
Basismodul
Basic module



MONTAGE PORTE + RAIL MONTAGE TÜR + SCHIENE ASSEMBLING DOOR + RAIL



Haut de porte - Oberer Türbereich - Upper door area

Recommandation : graissage régulier
Empfehlung : regelmäßig schmieren
Recommendation : grease regularly

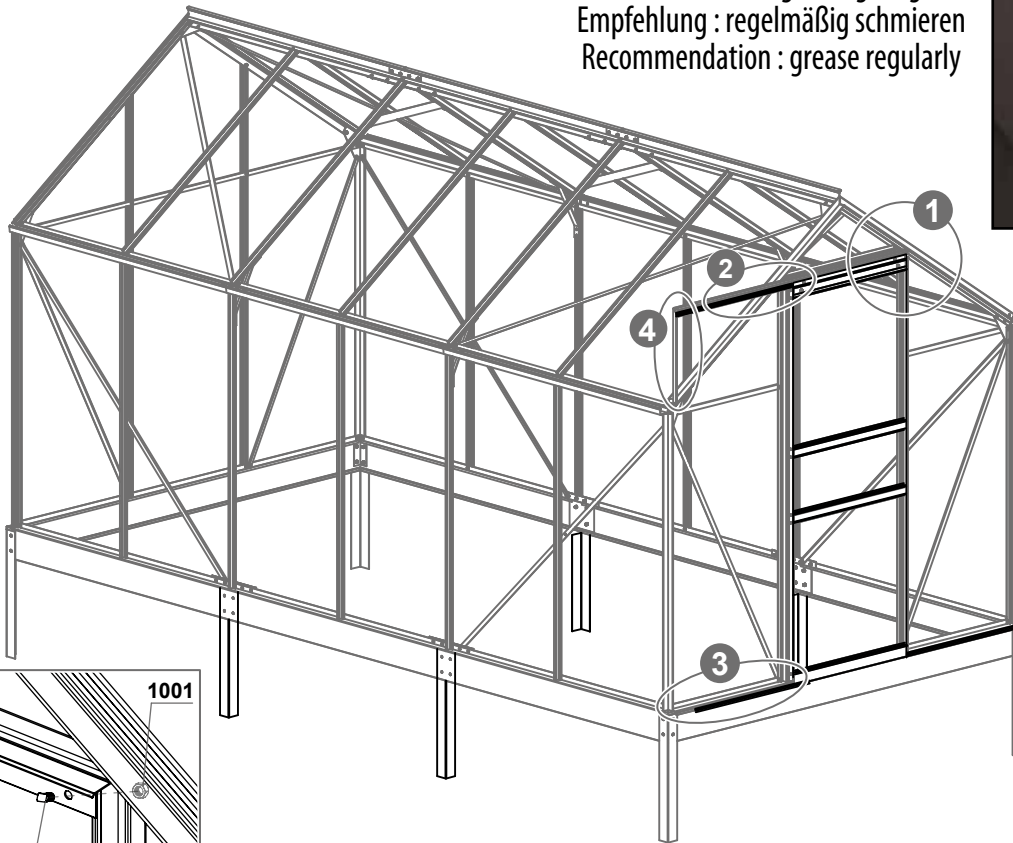

Module de base Basismodul Basic module



10001 x 1



33001 x 1



2009 x 1



1001 x 6



1002 x 2



1003 x 3

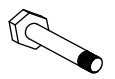

1006 x 1

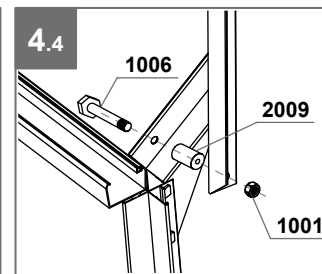
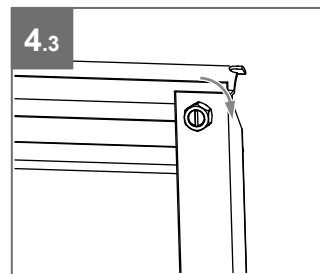
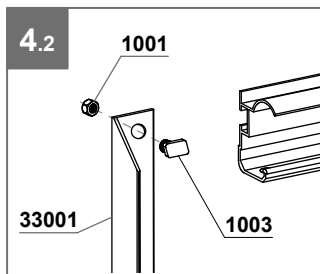
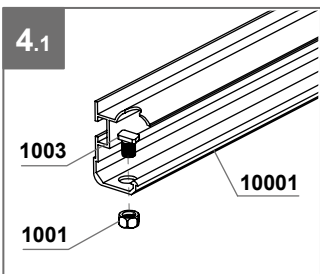
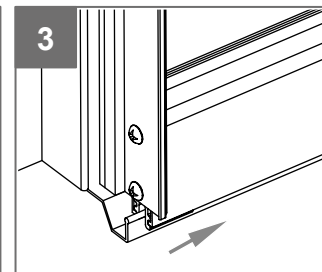
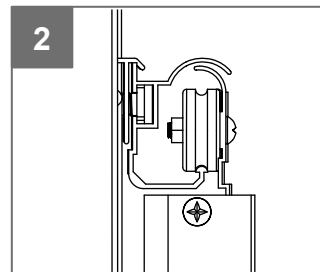
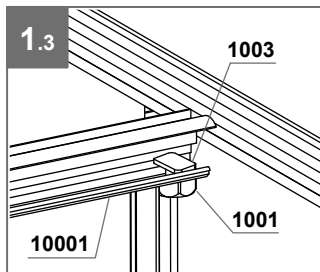
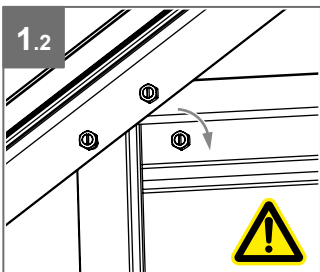
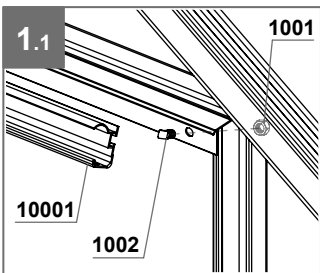

VITRAGE + POSE LUCARNE

 Nous vous conseillons d'installer les verres niveau par niveau (du bas vers le haut).



Clips de vitrage









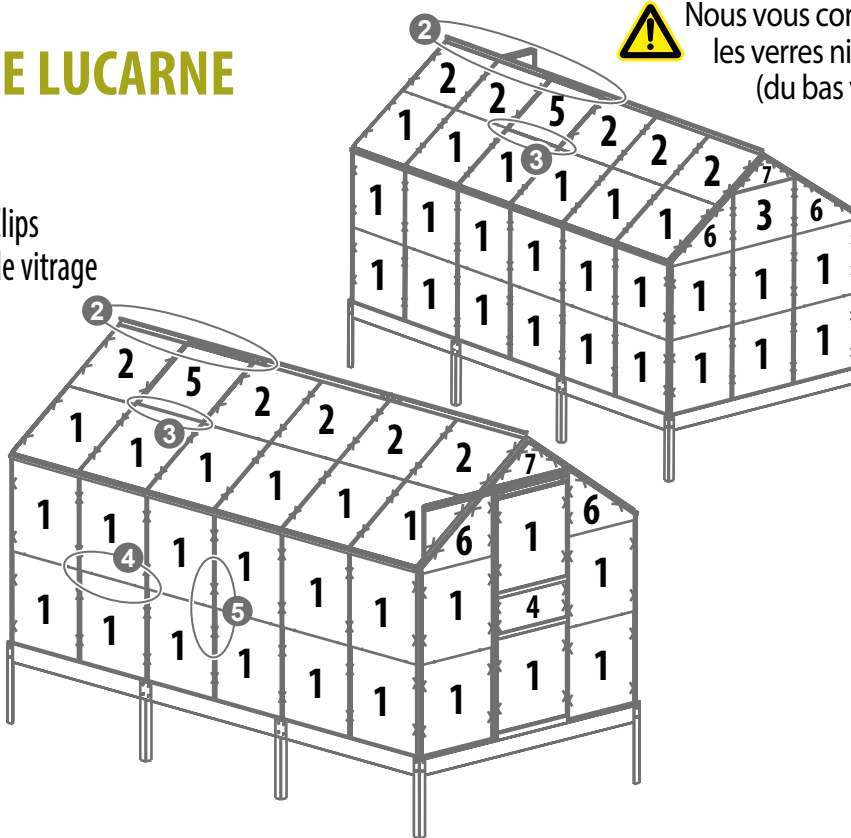

Crochets de vitrage



Lucarne
Vue extérieure







Module de base

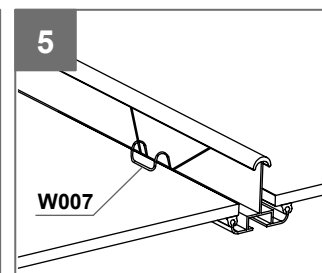
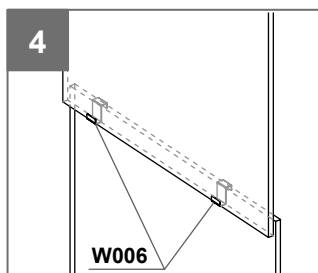
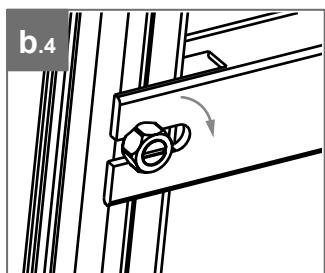
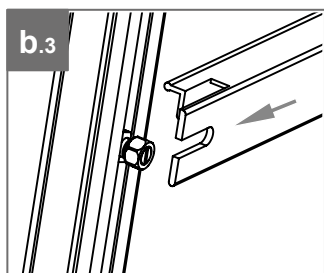
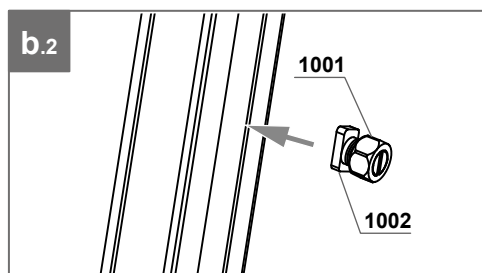
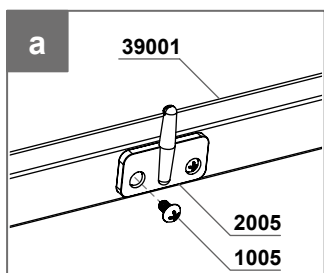
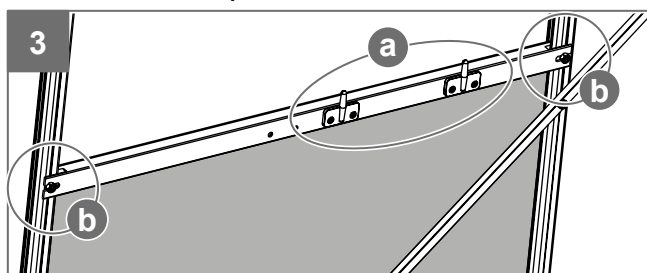
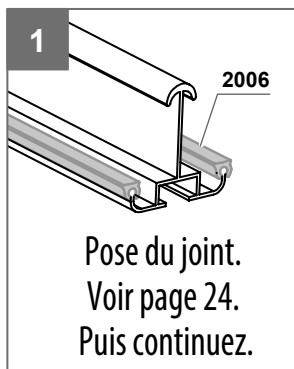







610 x 610	
1 x 36	
610 x 544	
2 x 7	
610 x 467	
3 x 1	
610 x 229	
4 x 1	
610 x 464/38	
6 x 4	
610 x 20/234/20	
7 x 2	
	
39001 x 1	
	
W006 x 52	
	
W007 x 204	

Il peut être nécessaire de dévisser temporairement certains profilés pour la mise en place des verres.
Resserer correctement les vis après la pose des verres.

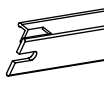

	
1001 x 2	
	
1002 x 2	
	
1005 x 4	
	
2005 x 2	

Module d'extension

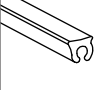
									
1 x 12	2 x 3	1001 x 2	1002 x 2	1005 x 4	2005 x 2	39001 x 1	W006 x 14	W007 x 60	2006 x 19m

VERGLASUNG + FENSTER EINBAUEN

! Wir empfehlen Ihnen, die Gläser Ebene für Ebene anzubringen (von unten nach oben).

Gewächshausklammern



Verglasungshaken



Fenster Außenansicht

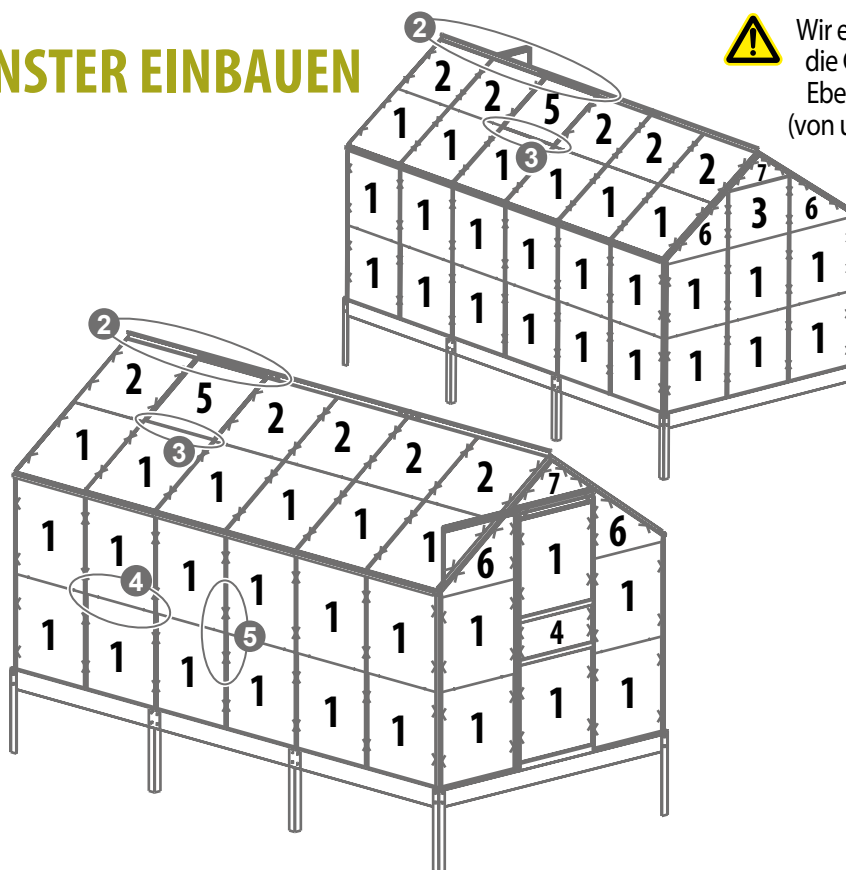

Basismodul

610 x 610	
1 x 36	
610 x 544	
2 x 7	
610 x 467	
3 x 1	
610 x 229	
4 x 1	
610 x 464/38	
6 x 4	
610 x 20/234/20	
7 x 2	
	39001 x 1
	W006 x 52
	W007 x 204

Zum Anbringen der Gläser kann es erforderlich sein, bestimmte Profile vorübergehend abzuschrauben. Schrauben Sie diese nach der Anbringung der Gläser wieder fest.

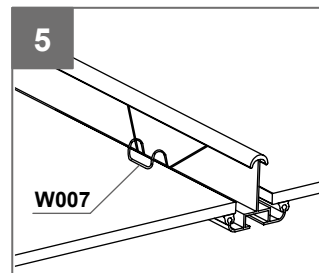
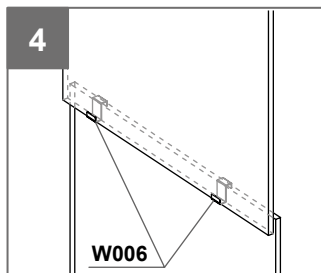
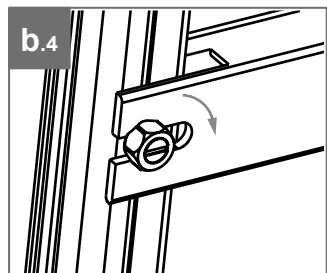
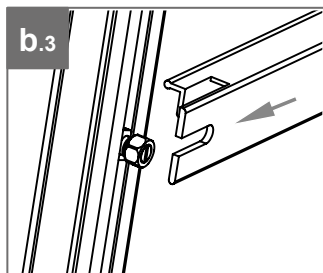
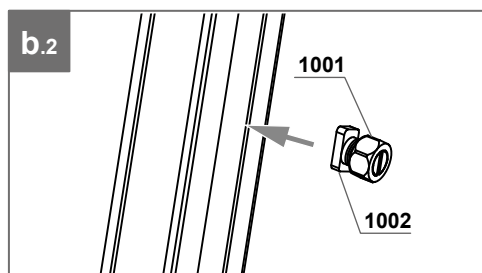
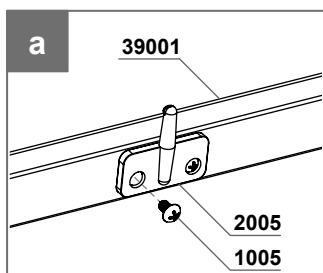
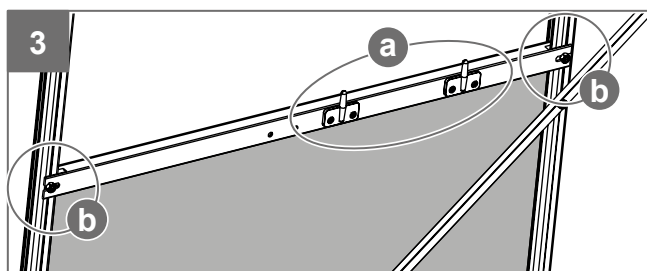
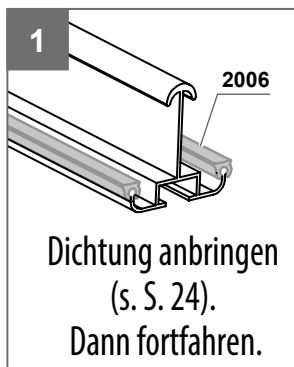

	1001 x 2
	1002 x 2
	1005 x 4
	2005 x 2

Erweiterungsmodul

1 x 12	2 x 3	1001 x 2	1002 x 2	1005 x 4	2005 x 2	39001 x 1	W006 x 14	W007 x 60	2006 x 19m

GLAZING + INSTALLING WINDOW

⚠ We advise you to install the glazing level by level (from bottom to top).



Glazing clips



Glazing hooks



Window Exterior view

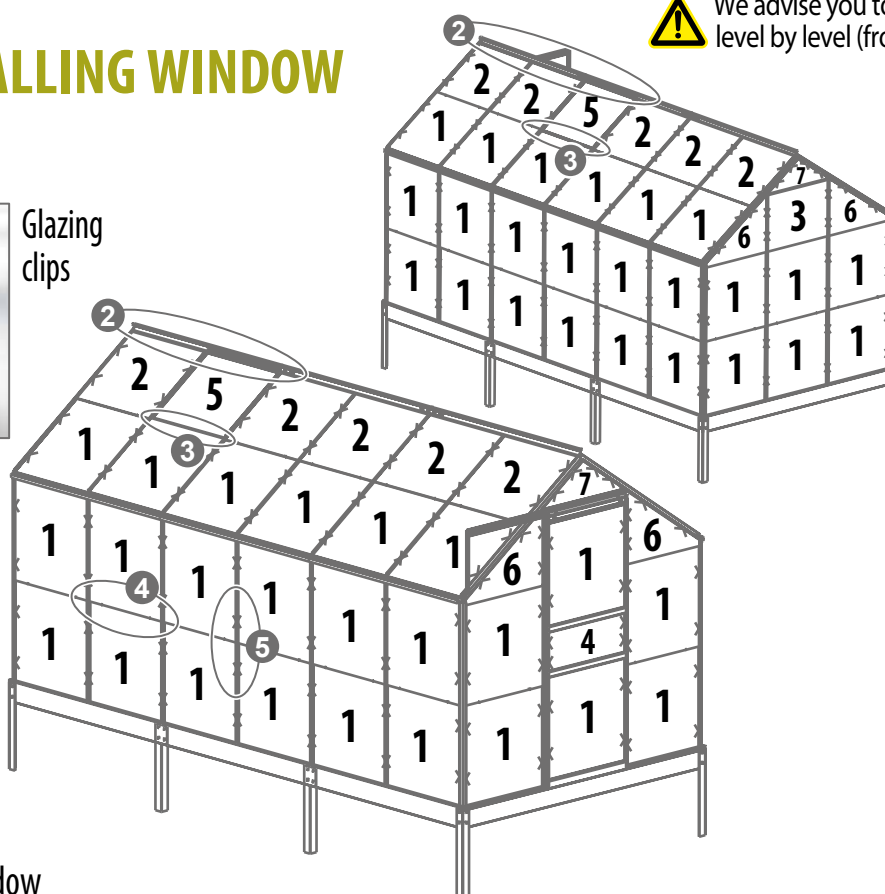

Some profiles may need to be temporarily unscrewed to install the glazing. Refix the screws correctly after installing the glazing.

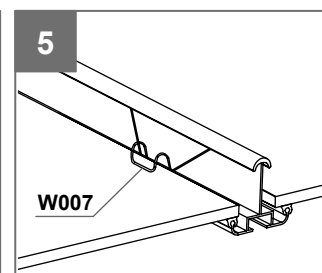
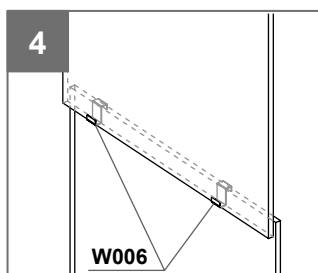
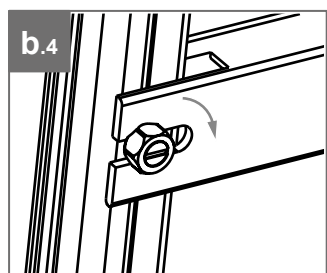
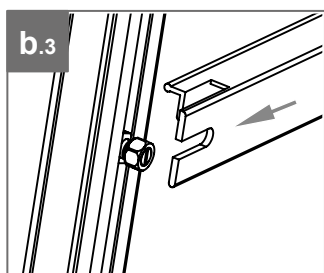
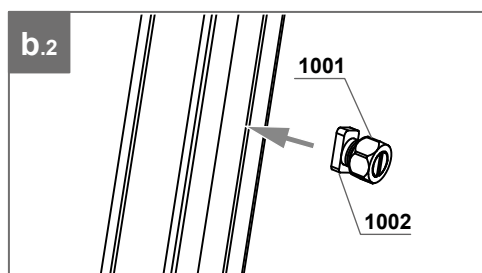
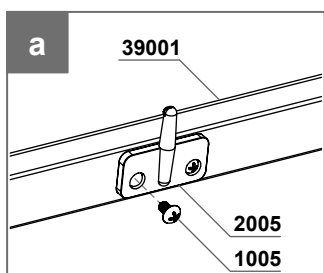
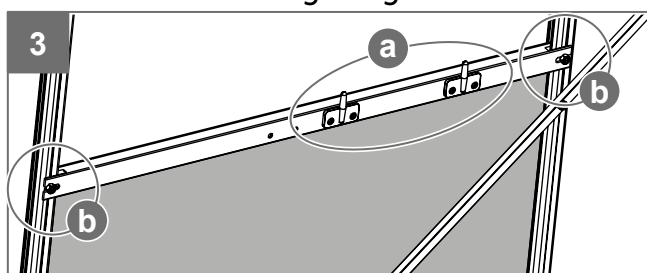
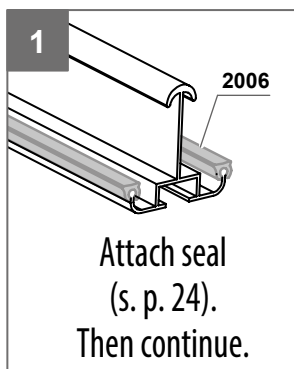

Basic module

610 x 610	
1 x 36	
610 x 544	
2 x 7	
610 x 467	
3 x 1	
610 x 229	
4 x 1	
610 x 464/38	
6 x 4	
610 x 20/234/20	
7 x 2	
39001 x 1	
W006 x 52	
W007 x 204	

1001 x 2	
1002 x 2	
1005 x 4	
2005 x 2	

Extension module

1 x 12	2 x 3	1001 x 2	1002 x 2	1005 x 4	2005 x 2	39001 x 1	W006 x 14	W007 x 60	2006 x 19m

MONTAGE DES PIÈCES PLASTIQUES

MONTAGE DER KUNSTSTOFFTEILE

INSTALLING THE PLASTIC PARTS

Module de base

Basismodul

Basic module

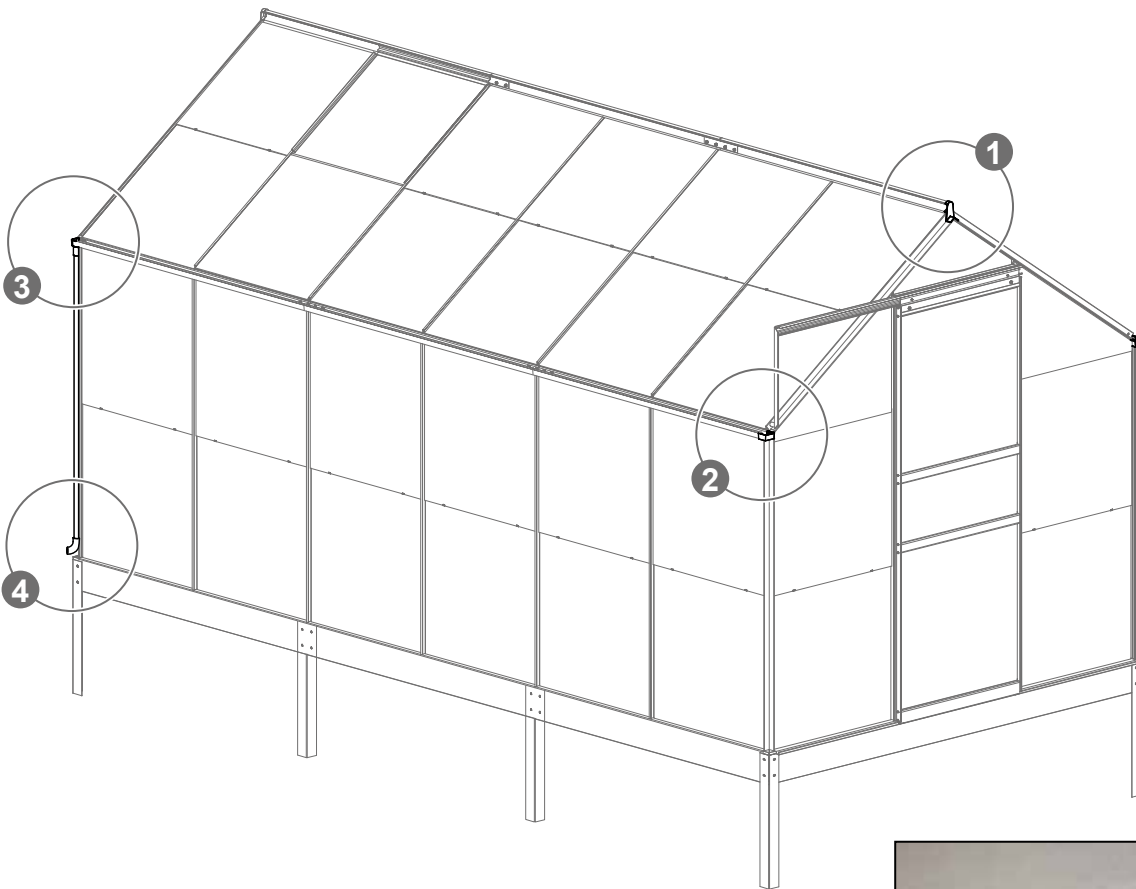

1005 x 4



2010 x 2

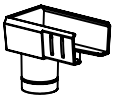

2022 x 2



2023 x 2



2028 x 2



2032 x 2

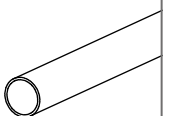

2041 x 2



58001 x 4



Détail embout de faîtière (pièce 2010)
Abdeckung der Firstspitze (Einzelteil 2010)
Roof ridge end cover (part 2010)

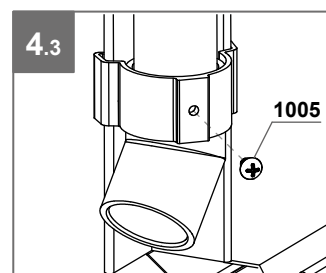
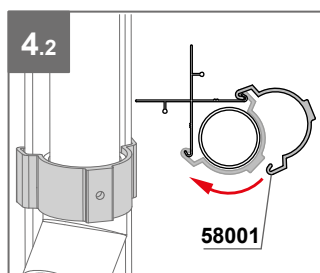
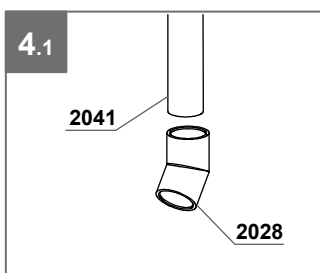
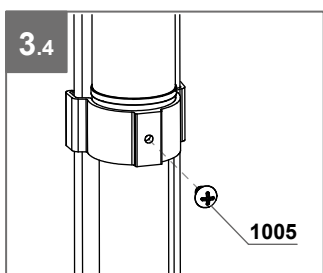
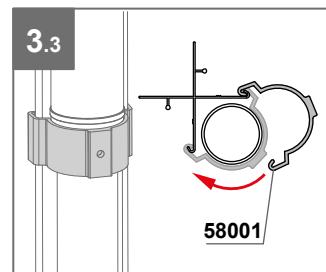
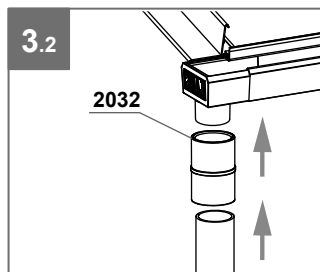
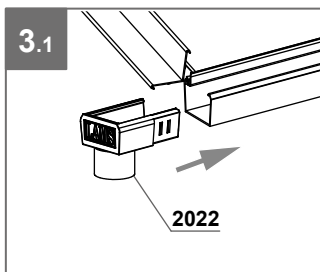
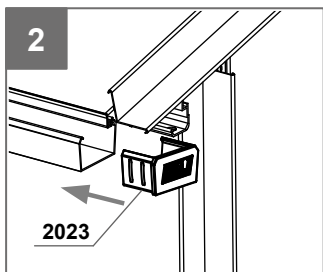
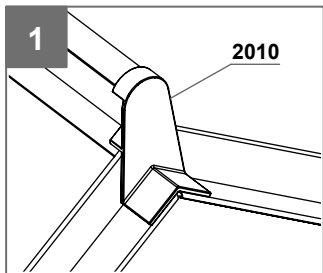

ACCESSOIRES COMPLÉMENTAIRES DISPONIBLES SUR NOTRE SITE ZUSÄTZLICHES ZUBEHÖR AUF UNSERER WEBSITE VERFÜGBAR ADDITIONAL ACCESSORIES AVAILABLE ON OUR WEBSITE

 WWW.SERRES-LAMS.COM

 WWW.GEWAECHSHAUS-LAMS.COM

QUELQUES ACCESSOIRES - EINIGE ACCESSOIRES - SOME ACCESSORIES



Système d'ombrage
Beschattungssystem
Shading system

*Permet de réguler la température de votre serre.
Ermöglicht die Temperatur zu regulieren.
Allows to regulate the temperature of your greenhouse.*



Kit descente de gouttière
Regenfallrohr-Set
Rain gutter kit

*Permet de récupérer l'eau de pluie.
Ermöglicht das Auffangen von Regenwasser.
Allows to collect rainwater.*



Ouverture automatique de lucarne
Automatischer Fensteröffner
Automatic window opener

*Système d'aération automatique (à partir de 17°C).
Automatisches Belüftungssystem (ab 17°C).
Automatic aeration system (from 17°C).*



Ventouse
Saugnapf
Suction cup

*Facilite le transport et la pose des verres.
Erleichtert das Tragen und Anbringen der Gläser.
Facilitates the transport and installation of the glass.*



Clips de vitrage à ressort
Federbelastete Gewächshausklammern
Spring glazing clips

*Permettent de maintenir le vitrage des serres.
Halten die Verglasung der Gewächshäuser.
Maintain the glazing of the greenhouses.*



Crochets de vitrage
Verglasungshaken
Glazing hooks

*Permettent de faire chevaucher deux vitrages.
Ermöglicht die Überlappung von zwei Glasscheiben.
Allows the overlap of two glasses.*

NOTES - NOTIZEN - NOTES

A series of horizontal dotted lines for writing notes, spanning the width of the page.



 WWW.SERRES-LAMS.COM

SERVICE CLIENTS

Site internet : www.sav-doviris.com

 WWW.GEWAECHSHAUS-LAMS.COM

KUNDENSERVICE

kontakt@gewaechshaus-lams.com